OWNER'S MANUAL

ELECTRIC CHAIN HOIST EM and SEM SERIES

250lbs through 1000lbs Capacity

Code, Lot and Serial Number

⚠ WARNING

This equipment should not be installed, operated, or maintained by any person who has not read and understood all the contents of this manual. Failure to read and comply with the contents of this manual can result in serious bodily injury or death, and/or property damage.

HARRINGTON
A KITO GROUP COMPANY



Table of Contents

Section	Page Number
1.0 Important Information and Warnings	4
1.1 Terms and Summary	
1.2 Warning Tags and Labels	
2.0 Technical Information.....	8
2.1 Specifications	
2.2 Dimensions	
2.3 ISO Classification	
3.0 Preoperational Procedures	13
3.1 Gearbox	
3.2 Chain	
3.3 Mounting Location	
3.4 Mounting the Hoist	
3.5 Electrical Connections and Wiring Diagrams	
3.6 Initial Inspection and Trial Operation	
4.0 Operation	24
4.1 Introduction	
4.2 Shall's and Shall Not's for Operation	
4.3 Hoist Controls	
5.0 Inspection	29
5.1 General	
5.2 Inspection Classification	
5.3 Preoperational Inspection	
5.4 Frequent Inspection	
5.5 Periodic Inspection	
5.6 Occasionally Used Hoists	

Section	Page Number
5.7 Inspection Records	
5.8 Inspection Methods and Criteria	
6.0 Maintenance & Handling	44
6.1 Lubrication – Load Chain, Hooks and Suspension	
6.2 Lubrication – Gearbox	
6.3 Motor Brake	
6.4 Single-phase Starting Capacitor Replacement	
6.5 Load Chain	
6.6 Storage	
6.7 Outdoor Installation	
6.8 Operational Environment	
7.0 Troubleshooting	51
7.1 Operation and Error Codes	
7.2 Troubleshooting Guide	
8.0 Warranty	59
9.0 Parts List	61

1.0 Important Information and Warnings

1.1 Terms and Summary

This manual provides important information for personnel involved with the installation, operation, and maintenance of this product. Although you may be familiar with this or similar equipment, it is strongly recommended that you read this manual before installing, operating, or maintaining the product.

Danger, Warning, Caution and Notice

Throughout this manual there are steps and procedures that can present hazardous situations. The following signal words are used to identify the degree or level of hazard seriousness.

⚠ DANGER Danger indicates an imminently hazardous situation which, if not avoided, **will** result in **death or serious injury**, and property damage.

⚠ WARNING Warning indicates an imminently hazardous situation which, if not avoided, **could** result in **death or serious injury**, and property damage.

⚠ CAUTION Caution indicates a potentially hazardous situation which, if not avoided, **may** result **minor or moderate injury** or property damage.

NOTICE Notice is used to notify people of installation, operation, or maintenance information which is important but not directly hazard-related.

⚠ CAUTION

These general instructions deal with the normal installation, operation, and maintenance situations encountered with the equipment described herein. The instructions should not be interpreted to anticipate every possible contingency or to anticipate the final system, crane, or configuration that uses this equipment. For systems using the equipment covered by this manual, the supplier and owner of the system are responsible for the system's compliance with all applicable industry standards, and with all applicable federal, state and local regulations/codes.

This manual includes instructions and parts information for a variety of hoist types. Therefore, all instructions and parts information may not apply to any one type or size of specific hoist. Disregard those portions of the instructions that do not apply.

Record your hoist's Code, Lot, and Serial Number (see **Section 9**) on the front cover of this manual for identification and future reference to avoid referring to the wrong manual for information or instructions on installation, operation, inspection, maintenance, or parts.

Use only Harrington authorized replacement parts in the service and maintenance of this hoist.

WARNING

Equipment described herein is not designed for and **MUST NOT** be used for lifting, supporting, or transporting people, or for lifting or supporting loads over people.

Equipment described herein should not be used in conjunction with other equipment unless necessary and/or required safety devices applicable to the system, crane, or application are installed by the system designer, system manufacturer, crane manufacturer, installer, or user.

Modifications to upgrade, rerate, or otherwise alter this equipment shall be authorized only by the original equipment manufacturer.

Equipment described herein may be used in the design and manufacture of cranes or monorails. Additional equipment or devices may be required for the crane and monorail to comply with applicable crane design and safety standards. The crane designer, crane manufacturer, or user is responsible to furnish these additional items for compliance. Refer to ANSI/ASME B30.17, "Cranes and Monorails (With Underhung Trolley or Bridge)"; and ANSI/ASME B30.2 "Overhead Gantry Cranes (Top Running Bridge, Single or Multiple Girder, Top Running Trolley Hoist)".

If a below-the-hook lifting device or sling is used with a hoist, refer to ANSI/ASME B30.9, "Slings" or ANSI/ASME B30.20, "Below-the-Hook Lifting Devices".

Hoists and cranes, used to handle hot molten material may require additional equipment or devices. Refer to ASTM E2349, "Standard Practice for Safety Requirements in Metal Casting Operations: Sand Preparation, Molding, and Core Making; Melting and Pouring; and Cleaning and Finishing".

Electrical equipment described herein is designed and built in compliance with Harrington's interpretation of ANSI/NFPA 70, "National Electrical Code". The system designer, system manufacturer, crane designer, crane manufacturer, installer, or user is responsible to assure that the installation and associated wiring of these electrical components is in compliance with ANSI/NFPA 70, and all applicable Federal, State and Local Codes.

Failure to read and comply with any one of the limitations noted herein can result in serious bodily injury or death, and/or property damage.

DANGER

HAZARDOUS VOLTAGES ARE PRESENT IN THE CONTROL BOX, OTHER ELECTRICAL COMPONENTS, AND CONNECTIONS BETWEEN THESE COMPONENTS.

Before performing ANY mechanical or electrical maintenance on the equipment, de-energize (disconnect) the main switch supplying power to the equipment; as well as lock and tag the main switch in the de-energized position. Refer to ANSI/ASSP Z244.1, "The Control of Hazardous Energy Lockout, Tagout and Alternative Methods".

The hoist units incorporate a Capacitor. Therefore, **DO NOT** perform ANY mechanical or electrical maintenance within 5 minutes of powering down to allow time for the capacitor to discharge.

Only trained and competent personnel should inspect and repair this equipment.

NOTICE

It is the responsibility of the owner/user to install, inspect, test, maintain, and operate a hoist in accordance with ANSI/ASME B30.16, "Overhead Underhung and Stationary Hoists", OSHA Regulations and ANSI/NFPA 70, National Electric Code. If the hoist is installed as part of a total lifting system, such as an overhead crane or monorail, it is also the responsibility of the owner/user to comply with the applicable ANSI/ASME B30 volume that addresses that type of equipment.

It is the responsibility of the owner/user to have all personnel that will install, inspect, test, maintain, and operate a hoist read the contents of this manual and applicable portions of ANSI/ASME B30.16, "Overhead Underhung and Stationary Hoists" OSHA Regulations and ANSI/NFPA 70, "National Electric Code". If the hoist is installed as part of a total lifting system, such as an overhead crane, the applicable ANSI/ASME B30 volume that addresses that type of equipment must also be read by all personnel.

If the hoist owner/user requires additional information, "Assembly/Reassembly" manual, or if any information in the manual is not clear, contact Harrington or the distributor of the hoist. Do not install, inspect, test, maintain, or operate this hoist unless this information is fully understood.

A regular schedule of inspection of the hoist in accordance with the requirements of ANSI/ASME B30.16 should be established and records maintained.

1.2 Warning Tags and Labels

The warning tag illustrated below in **Figure 1-1** is supplied with each hoist shipped from the factory. If the tag is not attached to your hoist's pendant cord, order a tag from your dealer and install it. Read and obey all warnings attached to this hoist. Tag is not shown actual size.



2.0 Technical Information

2.1 Specifications

2.1.1 Product Code

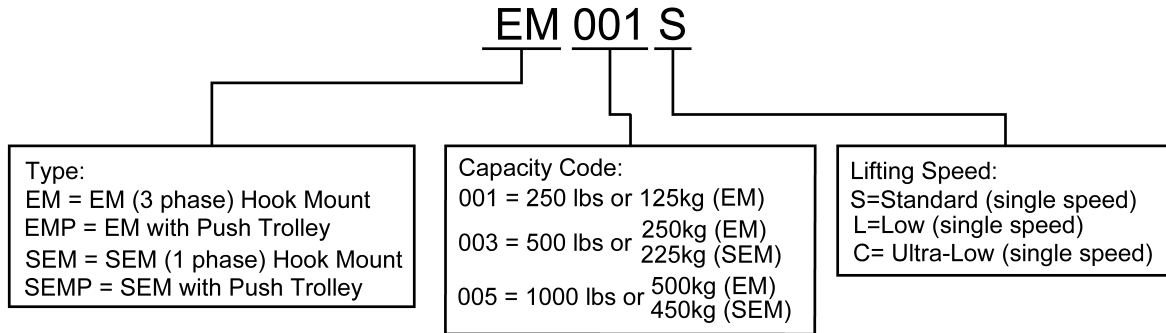

2.1.2 EM and SEM Models - Harrington EM series hoists are available in both three phase and single phase power. The EM model is the 3 phase version and the SEM model is the 1 phase version. Refer to Nameplate SP to verify the model by referencing the product code and voltage requirements. (See **Figure 2-1**)

Ensure the power supply is correct and that replacement parts are ordered for the correct model.

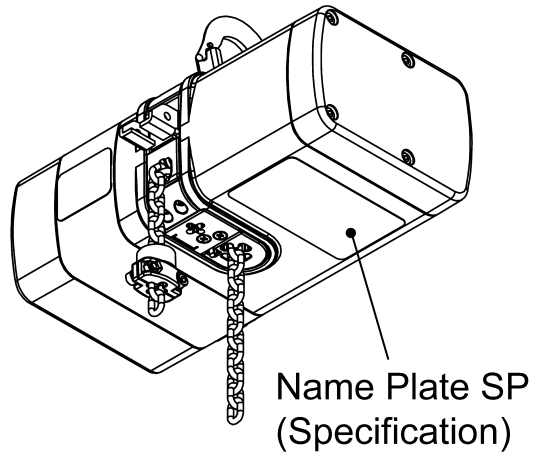

Figure 2-1 Identifying EM versus SEM Models

2.1.3 Operating Conditions and Environment

Temperature range*: -4° to +104°F (-20° to +40°C) – 3 phase
 14° to +104°F (-10° to +40°C) – 1 phase

*When operating 32F (0C) or lower, perform lifting and lowering with no load for 1 minute before operation to warm up the hoist.

Humidity: 85% or less

Noise Level: 70 dB or less (A scale: measured 1 meter away from electric chain hoist)

Enclosure Rating: IP65 for hoist and pendant

Supply Voltage: See **Table 2-1** below

Hoist Model	Product Category	Motor insulation	*Rated Voltage	
			50Hz	60Hz
EM	3-phase 230V class	B	200V	200-230V
	3-phase 460V class	B	380-400V	380-460V
SEM	1-phase 115V class	B	-	115-120V
	1-phase 230V class	B	-	220-230V

* All units are voltage specific

Control Voltage: 24VDC

Speed: Single

Duty Classification: ASME H4, ISO M5, FEM 2m

Intermittent Duty rating: 50% ED (ASME @ 65% capacity); 40% ED (FEM @ 100%capacity)

Max Number of starts per Hour: 300

Short Time Duty rating: 30min (Capacity 100%)

⚠ WARNING Do **NOT** use the electric chain hoist exceeding the short time ratings or the intermittent ratings. Do **NOT** operate the electric chain hoist outside of its rated voltage.

Table 2-2.1 Single Phase Hoist Specifications									
Cap. (lb)	Product Code	Lifting Motor 1 Phase 60 Hz				Load Chain Diameter (mm) x Chain Fall Lines	Net Weight w/10' lift (lb)	Weight for Additional One Foot of Lift (lb)	MAX Lift Available (ft)
		Lifting Speed (ft/min)	Output (Hp)	Rated Current* (amps)					
				@115 – 120V **	@220 – 230V				
500	SEM003L	12	0.22	4.6	2.3	4.0 x 1	30.9	0.24	120
1000	SEM005C	6	0.22	4.6	2.3	4.0 x 2	35.3	0.48	60

* All units are voltage specific

** 115V units supplied with a 15 Amp Plug. All other voltages will require a plug (not available through Harrington Hoists)

Table 2-2.2 Three Phase Hoist Specifications													
Cap. (lb)	Product Code	Lifting Motor 3 Phase 60 Hz				Lifting Motor 3 Phase 50 Hz				Load Chain Diameter (mm) x Chain Fall Lines	Net Weight w/10' lift (lb)	Weight for Additional One Foot of Lift (lb)	MAX Lift Available (ft)
		Lifting Speed (ft/min)	Output (HP)	Rated Current* (amps)		Lifting Speed (ft/min)	Output (HP)	Rated Current* (amps)					
				@200 - 230V	@380 - 460V			@200V	@380 - 400V				
250	EM001S	32	0.34	1.4	0.7	26	0.34	1.4	0.6	4.0 x 1	30.9	0.24	120
500	EM003L	16	0.34	1.4	0.7	13	0.34	1.4	0.6	4.0 x 1	30.9	0.24	120
1000	EM005C	8	0.34	1.4	0.7	6.5	0.34	1.4	0.6	4.0 x 2	35.3	0.48	60

* All units are voltage specific

2.2 Dimensions

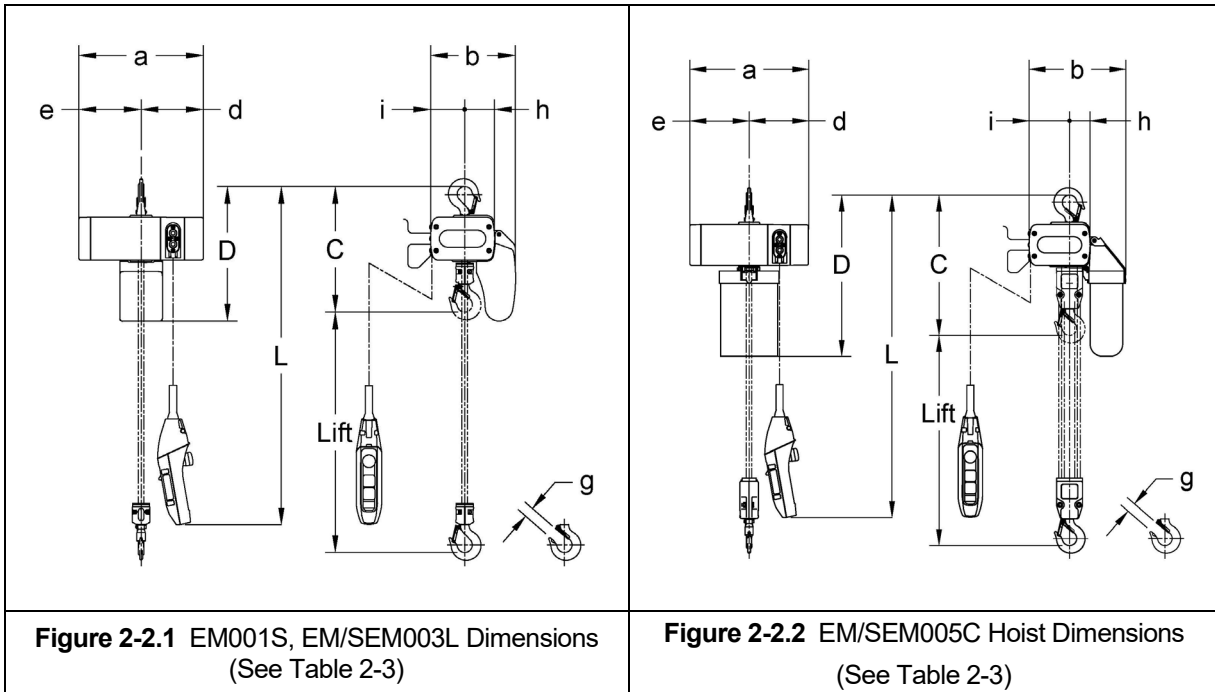

Product Code	Headroom C (in)	D (in)	a (in)	b (in)	d (in)	e (in)	g (in)	h (in)	i (in)
EM001S	11.6	12.4	11.5	7.9	5.7	5.7	0.9	2.8	3.1
EM003L SEM003L	11.6	12.4	11.5	7.9	5.7	5.7	0.9	2.8	3.1
EM005C SEM005C	13.6	16.1	11.5	9.4	5.7	5.7	0.9	2	3.9

*Dimensions are based on the standard lift of 10 feet.

<p>T = Top Hook B = Bottom Hook Units = inch</p>							
Capacity Code	Hook**	a	b	c	d	e	g
EM001S, EM/SEM003L, EM/SEM005C	B & C	0.8	0.5	0.7	0.5	1.4	1.4

*Refer to **Section 5.8** for inspection dimensions and limits.

**B=body hook, C=load chain hook

2.3 ISO Classification

Table 2-5 Hoist classifications as determined by ISO / JIS						
Loading Status*	Service Limit					
	800	1600	3200	6300	12500	25000
Light				M4	M5	M6
Medium			M4	M5	M6	
Heavy		M4	M5	M6		
Ultra Heavy	M4	M5	M6			

*** Loading Status**

Light ($L < 50\%$): A case where the capacity is rarely applied. Usually the hoist is used with a light load. Medium ($50\% \leq L < 63\%$): A case where the capacity is applied considerably frequently. Usually the hoist is used with a medium load. Heavy ($63\% \leq L < 80\%$): A case where the capacity is applied considerably frequently. Usually the hoist is used with a heavy load. Ultra heavy ($80\% \leq L$): A case where the capacity is applied constantly.

As Indicated by Table 2-5:

State of Loading and Total Duration of Use are the factors used to determine the hoist classification that should be used: M1, M2, M3, M4, M5, or M6. Cross referencing the two factors with one another will lead to a classification choice in the chart.

- Example: A hoist that would be subjected frequently to the maximum load and, normally, to loads of heavy magnitude (a “heavy” state of loading), that requires a life span of 1600 hours should be in classification group M5.
- Example 2: A hoist that would be subjected very rarely to the maximum load and, normally, to light loads (a “light” state of loading), that requires a life span of 6300 hours should be in classification group M4.

Duration of Use Calculation:

$$\text{Annual Operating Time (h)} = \text{Operating Time per Day} * \text{Annual Working Days}$$

$$\text{Cumulative Operating Time (h)} = \text{Annual Operating Time} * \text{Years Passed}$$

$$\text{Remaining Lifetime (h)} = \text{Service Limit} - \text{Cumulative Operating Time}$$

$$\text{Years of Remaining Lifetime} = \frac{\text{Remaining Lifetime}}{\text{Annual Operating Time}}$$

Service Limit (h): refer to Table 2-5.

3.0 Preoperational Procedures

3.1 Gearbox

3.1.1 The gearbox is filled with the correct amount of grease at the time of shipment.

3.1.2 Refer to **Section 6.2** when replacing the gear grease.

3.2 Chain

- 3.2.1 **⚠ WARNING** Never operate the hoist with incorrect, missing, or damaged chain components. Ensure that all chain components are in the correct location and properly installed as shown in **Figure 3-1** and **3-2**. The stopper shall be installed on the third or fourth link from the end of the chain (Note: this must be a seated link). If the stopper position is incorrect, it could cause the load chain to break.

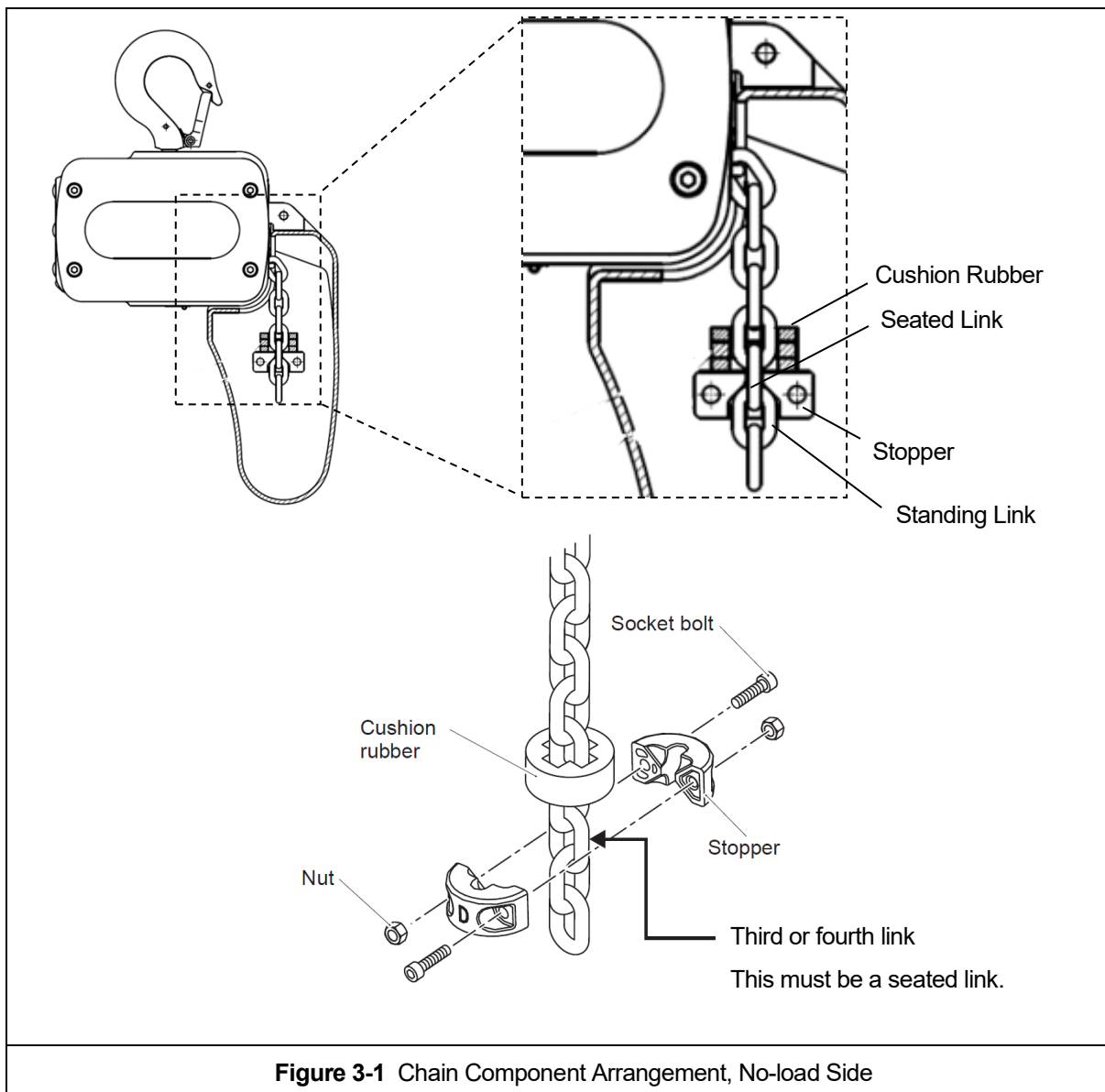

*Tightening torque for the Stopper Bolt: 8.4 N-m (6.2 lb-ft)

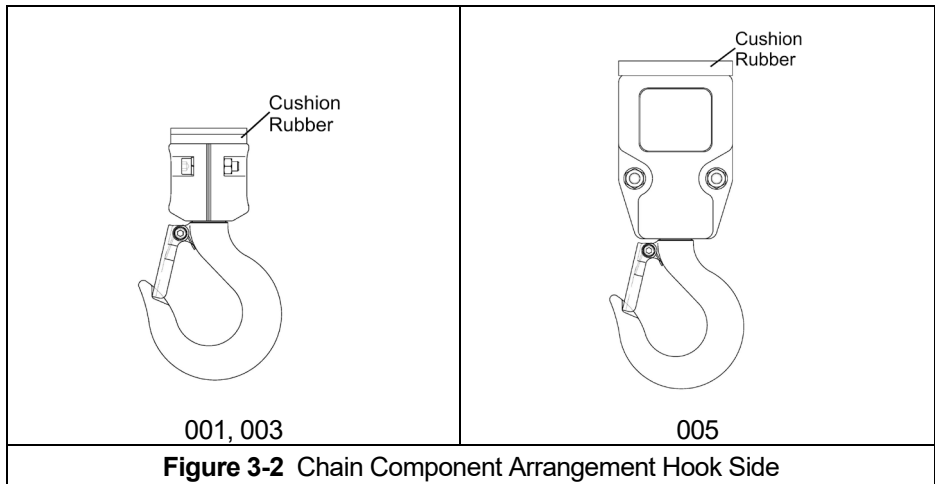

Figure 3-2 Chain Component Arrangement Hook Side

*Tightening torque for the hook yoke bolts for 001 and 003: 8.4 N-m (6.2 lb-ft)

*Tightening torque for the hook yoke bolts for 005: 5.8 N-m (4.3 lb-ft)

3.2.2 Canvas or Plastic Chain Container – When installing the chain container, refer to **Figure 3-3**. Install a Socket Bolt through one side of the Chain Container then through the Chain Container Bracket and the other side of the Chain Container. For Canvas Chain Container, install the second Socket Bolt through one side of the Chain Container then through Chain Container Bracket C and the other side of the Chain Container. Screw the Nut on to the Socket Bolt and tighten it securely. The Socket Bolt must protrude from the end face of the Nut by three threads or more. The free end of the chain is not attached to the hoist body and the chain stopper is installed on the third or fourth seater link from the free end (see **Figure 3-1**). To place the chain into the Chain Container, feed the free end of the chain into the container. Take care to avoid twisting or tangling the chain. NEVER put all the chain into the container at once.

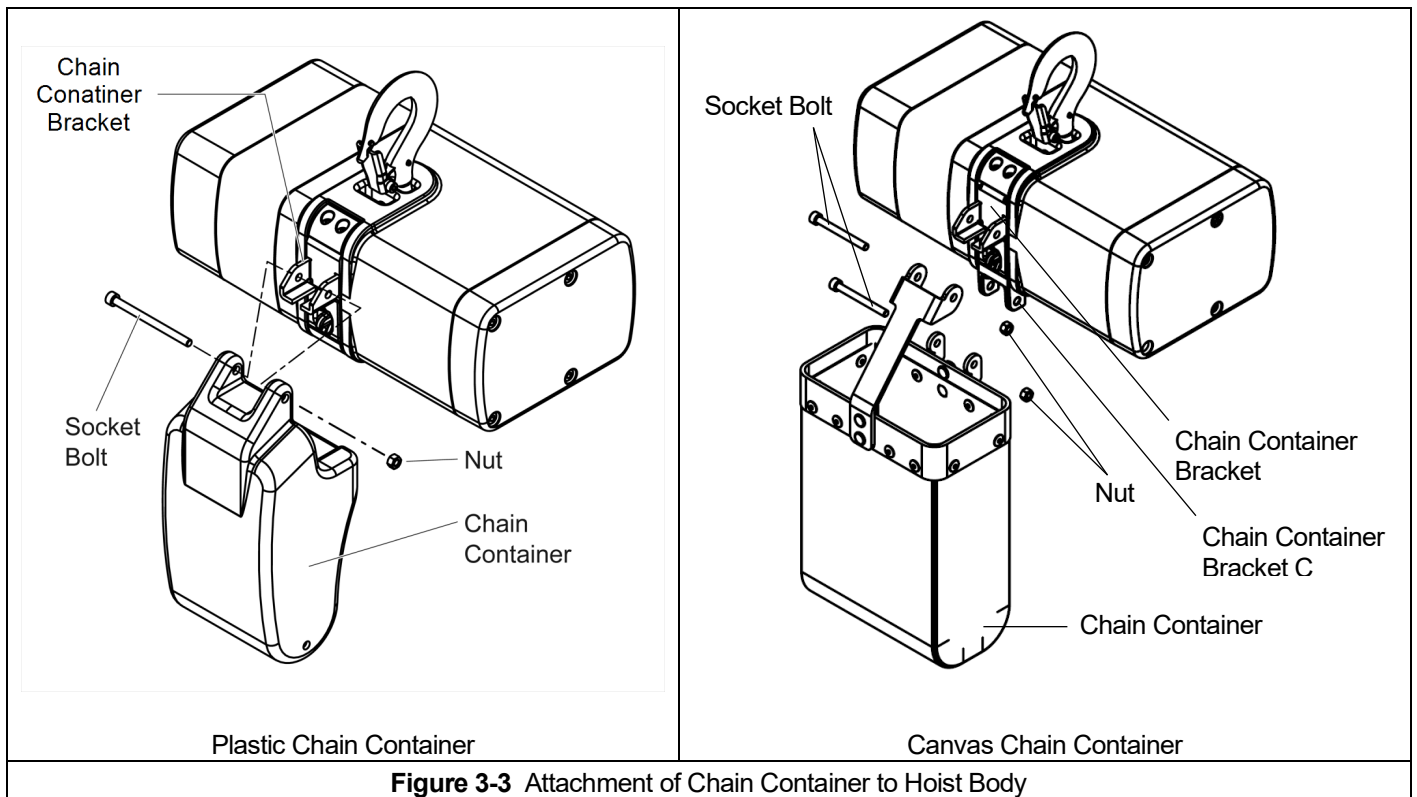
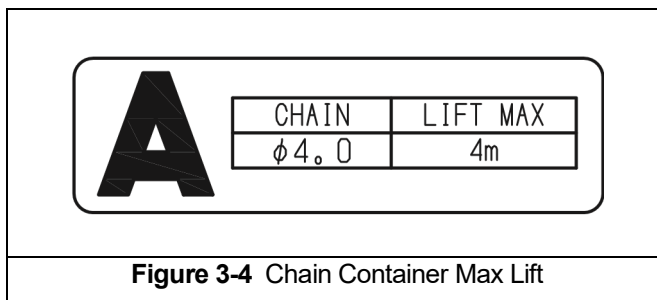
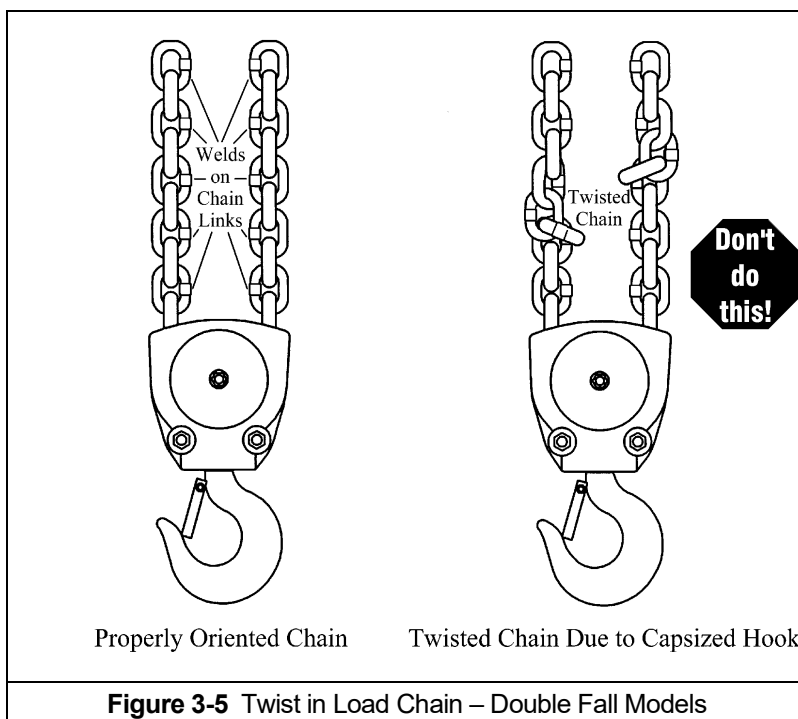

Figure 3-3 Attachment of Chain Container to Hoist Body

- 3.2.3 **⚠ WARNING** Each chain container indicates the diameter and the maximum length of the load chain that can be stored in the container (refer to **Figure 3-4**). Be sure to check the label before installation. The amount of chain the container must hold is equal to the lift on the hoist. **Do NOT** use a chain container with a storage capacity less than the lift length on the hoist.



- 3.2.4 **⚠ WARNING** Verify that the load chain is not twisted or tangled prior to operating the hoist. Make sure the bottom hook on double fall models (EM005C/SEM005C) is not capsized. See **Figures 3-5** and **3-6**. Correct all chain irregularities before conducting the first hoist operation.



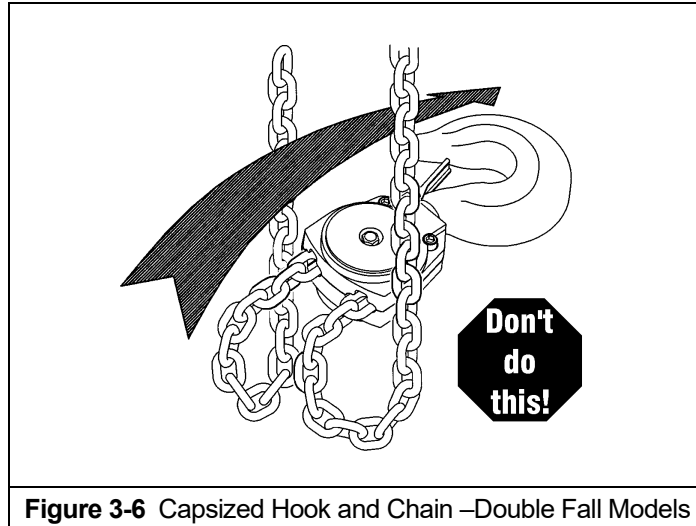

3.3 Mounting Location

- 3.3.1 **⚠ WARNING** Prior to mounting the hoist ensure that the suspension and the supporting structure are adequate to support the hoist and its loads. If necessary consult a professional that is qualified to evaluate the adequacy of the suspension location and its supporting structure.
- 3.3.2 **NOTICE** See **Section 6.7** for outdoor installation considerations.

3.4 Mounting the Hoist

- 3.4.1 Manual Trolley - Follow instructions in Owner's Manual provided with the trolley.
- 3.4.2 Hook Mounted to a Fixed Location - Attach the hoist's top hook to the fixed suspension point.
- 3.4.3 **⚠ WARNING** Ensure that the fixed suspension point rests on the center of the hook's saddle and that the hook's latch is engaged. Ensure that the Body Hook and body can swing freely. (**Do NOT** restrain the Body Hook and body when in use.)
- 3.4.4 Multi-point (simultaneous operation) - It is the responsibility of the End User and/or Owner/Operator to ensure the lifting operation does not result in any overload conditions, and the products are used within the capabilities and limitations published within the Owner's Manual. This includes situations where two or more pieces of lifting equipment are used to simultaneously lift and/or traverse a single load. The lifting systems design WHICH IS THE RESPONSIBILITY OF THE END USER AND/OR OWNER/OPERATOR AND NOT KITO CORPORATION OR ANY OF ITS SUBSIDIARIES INCLUDING BUT NOT LIMITED TO HARRINGTON HOISTS, INC., AND PEERLESS CHAIN COMPANY shall be specified appropriately for the loadings, reasonably foreseeable misuse and be capable of synchronized operation without creating an overload condition. Operator training shall be conducted to ensure lifting is performed in a safe manner. Where appropriate a written lifting and rigging plan should be applied to ensure safety.

3.5 Electrical Connections and Wiring Diagrams

- 3.5.1 **⚠ WARNING** If the hoist was supplied without a Power Supply Cable. The installer must use a cULus List power supply cable Type SJ, SJT, SO, SOO, SOOW, ST, STO or of a type at least equally serviceable for the particular application. Rated 90C, 600V minimum. Refer to total AMP draw and NEC® (ANSI/NFPA 70, “National Electric Code”) guidelines when sizing appropriate Power Supply Cable gauge. Always consult with a qualified person when appropriate Power Supply Cable sizing is in question.
- 3.5.2 **⚠ WARNING** Ensure that the phase and the voltage of the electric power supply is proper for the hoist. If using a generator, ensure it is an inverter type.
- 3.5.3 **⚠ CAUTION** Short-circuit current rating, 5kA RMS symmetrical, 460V maximum.
- 3.5.4 **⚠ CAUTION** Do **NOT** apply electronic soft-start control or voltage varying controls to the hoist. Use of such devices may cause the motor brake and other electrical components to malfunction.
- 3.5.5 **⚠ DANGER** Before proceeding, ensure that the electrical supply for the hoist has been de-energized (disconnected). Lock out and tag out in accordance with ANSI/ASSP Z244.1 “The Control of Hazardous Energy Lockout, Tagout and Alternative Methods”.
- 3.5.6 **⚠ DANGER** To avoid a shock hazard, Do **NOT** perform **ANY** mechanical or electrical maintenance on the hoist within 5 minutes of de-energizing (disconnecting) the trolley or hoist. This time allows the internal capacitor to safely discharge.
- 3.5.7 **⚠ DANGER** Do **NOT** remove power to the hoist during operation.
- 3.5.8 The Wiring Diagram is accessible from the QR code label located as shown in **Figure 3-7**. Wiring Diagram for EM (**Figure 3-8**) or SEM (**Figure 3-9**) will be displayed.

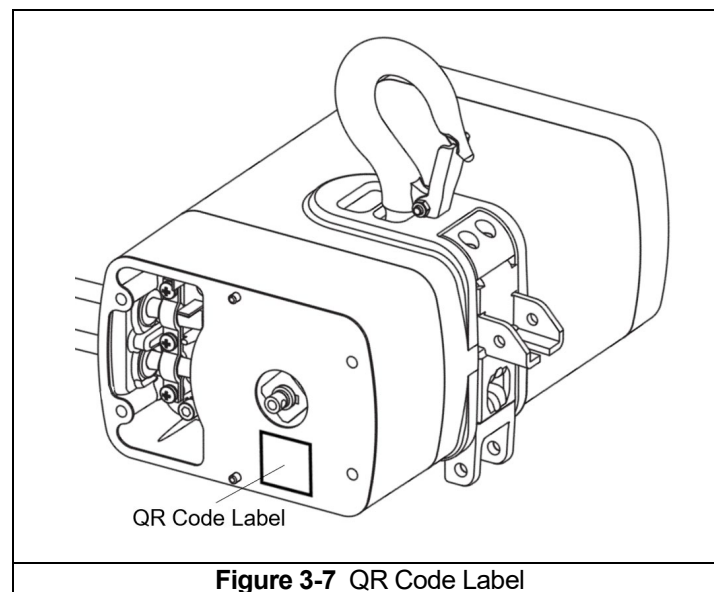

Parts No	NAME
1 B11	Electromagnetic Brake
2 G11	Rectifier
3 M11	Hoist Motor
4 CN~	Plug/Socket/Connector
5 TP11	Motor Thermal Protector
6 LS11	Upper Limit Switch
7 JP~	Jumper Pin
8 TB11	Terminal Block

SSR SW2 Settings (Parameter Select)

1	OFF	3 Phase Motor
2	OFF	250 lbs
3	OFF	500 lbs
4	OFF	1000 lbs

Note

- 1.Chain Hoist (EM)
Model: 001S/003L/005C
- 2.Operation Type
Hoist: Single Speed (SSR)
- 3.Power Supply
3 Phase 230 V Class
50 Hz 200 V
60 Hz 200 - 230 V
3 Phase 460 V Class
50 Hz 380 - 400 V
60 Hz 380 - 460 V
- 4.Push Button Connection
Direct Connection

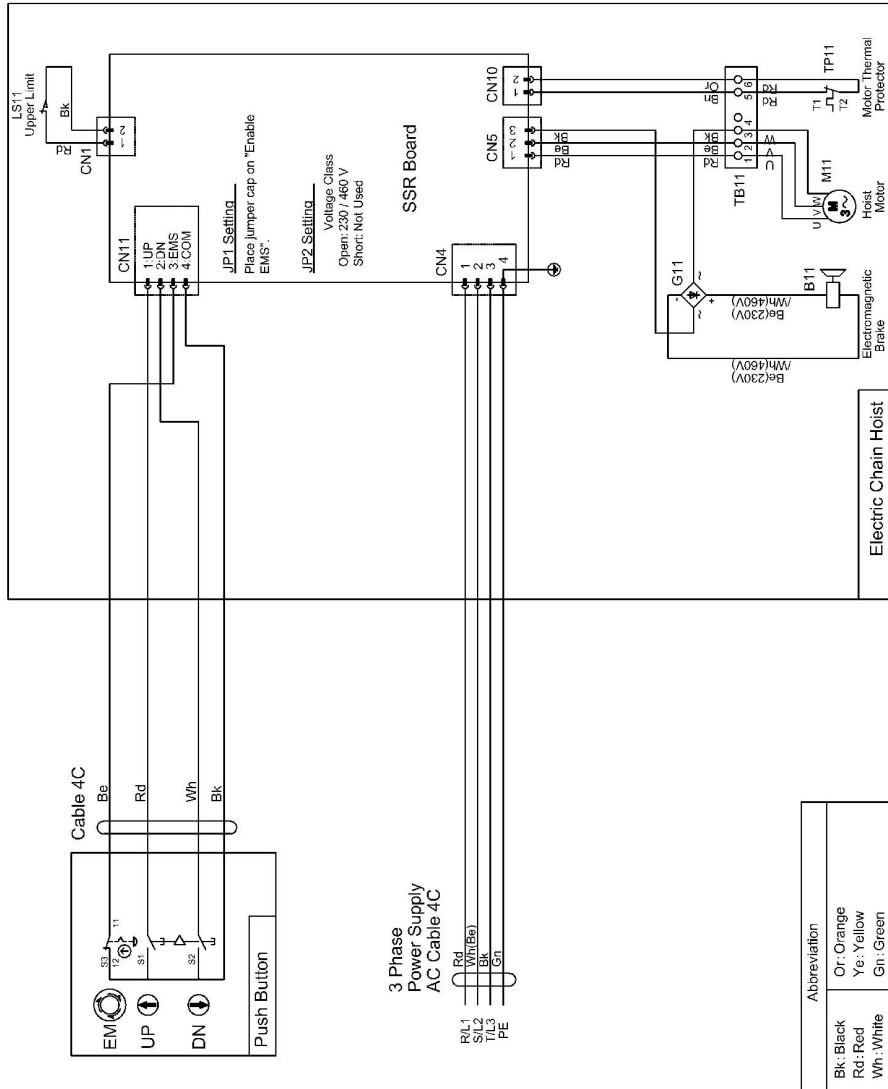

Abbreviation	
Bk: Black	Or: Orange
Rd: Red	Ye: Yellow
Wh: White	Gn: Green
Be: Blue	EMS: Emergency Stop
Bn: Brown	UP: UP
	DN: Down

Figure 3-8 3-Phase EM Wiring Diagram

Parts No	NAME
1	B11 Electromagnetic Brake
2	G11 Rectifier
3	M11 Hoist Motor
4	CN~ Plug/Socket/Connector
5	TP11 Motor Thermal Protector
6	LS11 Upper Limit Switch
7	JP~ Jumper Pin
8	C11 Capacitor
9	R11 Resistor
10	TB11 Terminal Block

SSR SW2 Settings (Parameter Select)

1	ON	1 Phase Motor
2	OFF	230 V Class
	ON	115 V Class

3	OFF	500 lbs
	ON	1000 lbs
4	OFF	-

Note

- 1.Chain Hoist (SEM)
Model: 003L/005C
- 2.Operation Type
Hoist: Single Speed (SSR)
- 3.Power Supply
1 Phase 115 V Class
60 Hz 115 - 120 V
1 Phase 230 V Class
60 Hz 220 - 230 V
- 4.Push Button Connection
Direct Connection

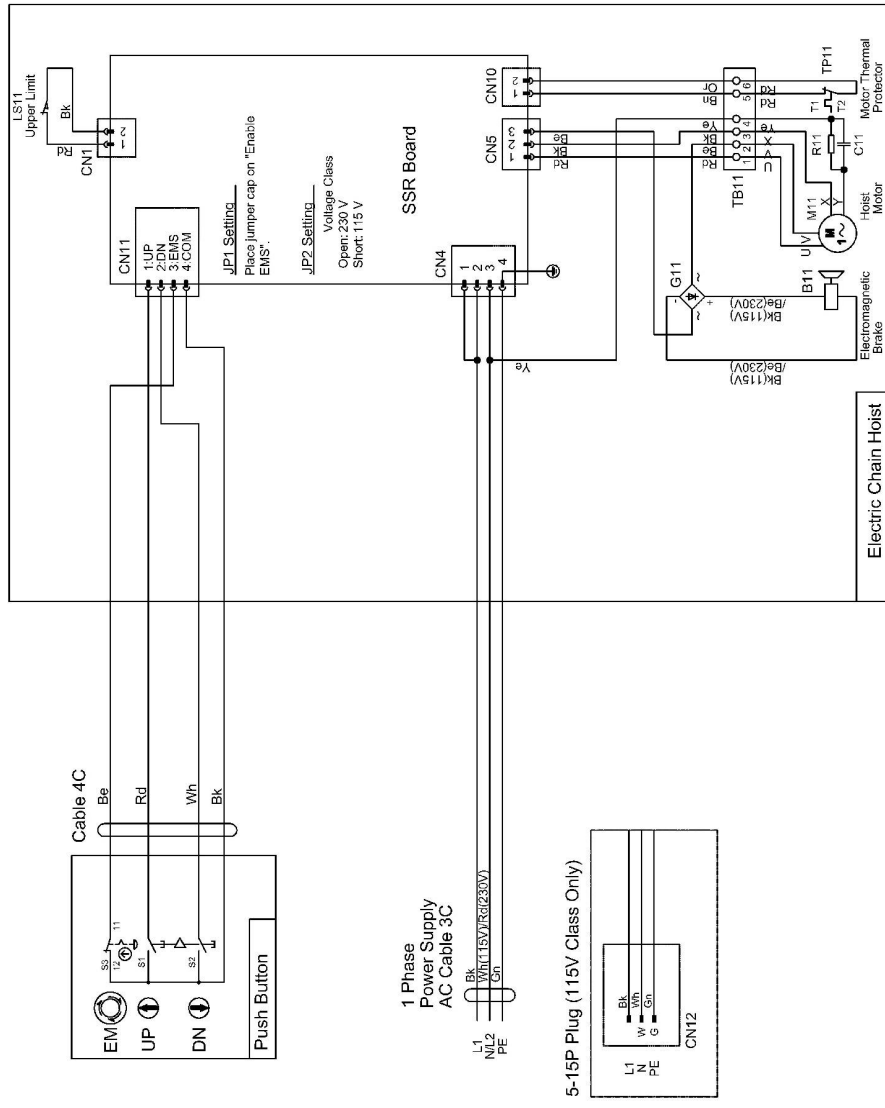

Abbreviation	
Bk: Black	Or: Orange
Rd: Red	Ye: Yellow
Wh: White	Gn: Green
Be: Blue	EMS: Emergency Stop
Bn: Brown	UP: UP
	DN: Down

Figure 3-9 Single-Phase SEM Wiring Diagram

- 3.5.9 The hoist is controlled by a pendant with two push buttons – one for raising and one for lowering and includes a red emergency stop. The Power Cable and Pendant Cord are attached to the electric chain hoist at shipping. When it is necessary to replace or remove/replace them, observe the following procedures.

Removing the Power Cable and the Pendant Cord

- Remove the controller cover and the 3 machine screws that hold the Cable Clamp (see **Figure 3-10**).
 - Three Phase
 - Disconnect the connectors inside the hoist (see **Figure 3-11**).
 - Single Phase
 - Disconnect the connectors inside the hoist (see **Figure 3-11**).
 - Pull up the orange levers of the splicing connector attached on the Power Cable and disconnect all the three lead wires (yellow and white or red) (see **Figure 3-11**).
 - Remove the 4 machine screws that are used for Holder Plate A and Holder Plate B, and shift the holder plates away from the body onto the cables (see **Figure 3-12**).
- ⚠ CAUTION** When Holder Plate B is removed from body, the Strain Relief Cable will come off.
- Remove Power Cable and the Pendant Cord from the hoist body.

Installing the Power Cable and/or the Pendant Cord

- Replacement Power Cable and Pendant Cord comes with the Holder Plate and packing already installed.
 - Insert the Power Cable (with 4P plug connector and Holder Plate A) into the top hole and the Pendant Cord (with 4P socket connector and Holder Plate B) into the bottom hole. Secure the Holder Plate A/B with the 4 Pan Head Machine Screws (see **Figure 3-12**).
- ⚠ CAUTION** When mounting Holder Plate B, ensure that the Strain Relief Cable is secured by the Cord Support (see **Figure 3-11**).
- Connect the Connectors to its appropriate mate inside the hoist (see **Figure 3-13**).
 - Secure the Cable Clamp with the Pan Head Machine Screws (see **Figure 3-10**) and reinstall the controller cover.

If the hoist is hook mounted to a fixed support, ensure that the Power Cable is properly installed and supported between the hoist and the electrical power supply.

If the hoist is installed on a manual trolley, then the Power Cable must be installed along the beam that the trolley runs on. For curved beams a special cable suspension system will be needed, and this instruction does not apply. For straight beams install the Power Cable as follows:

- Install a guide wire system parallel to the beam.
- For a manual trolley the guide wire should be positioned within 3 feet of the hoist body.
- Use the Cable Trolleys supplied with the hoist to suspend the Power Supply Cable from the guide wire. Space the Cable Trolleys every 5 feet.

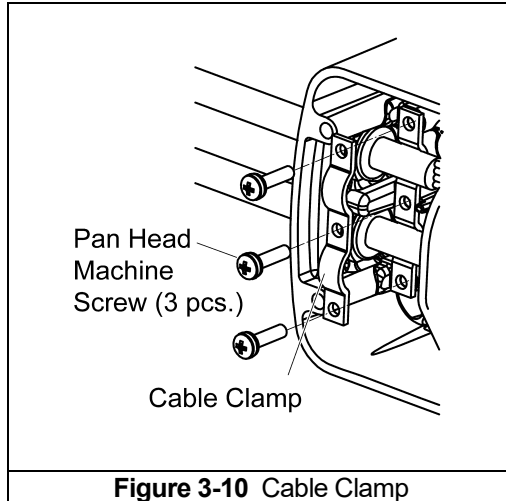

*Tightening torque for the Pan Head Screws: 1.1 N-m (0.81 lb-ft)

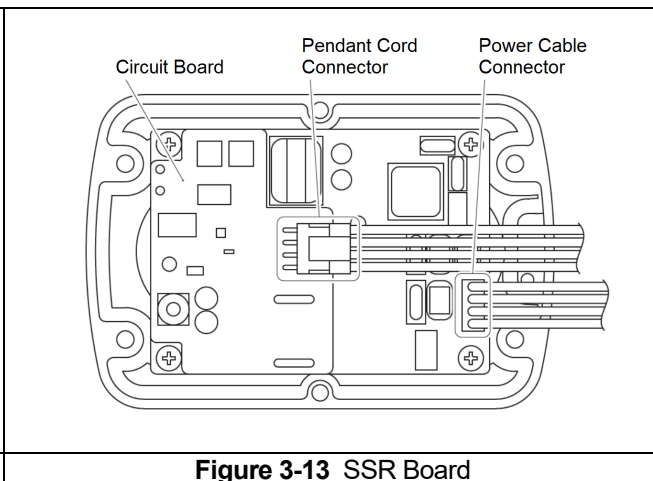
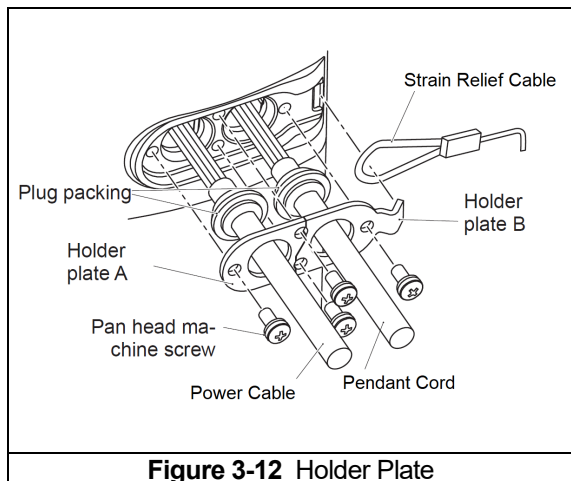
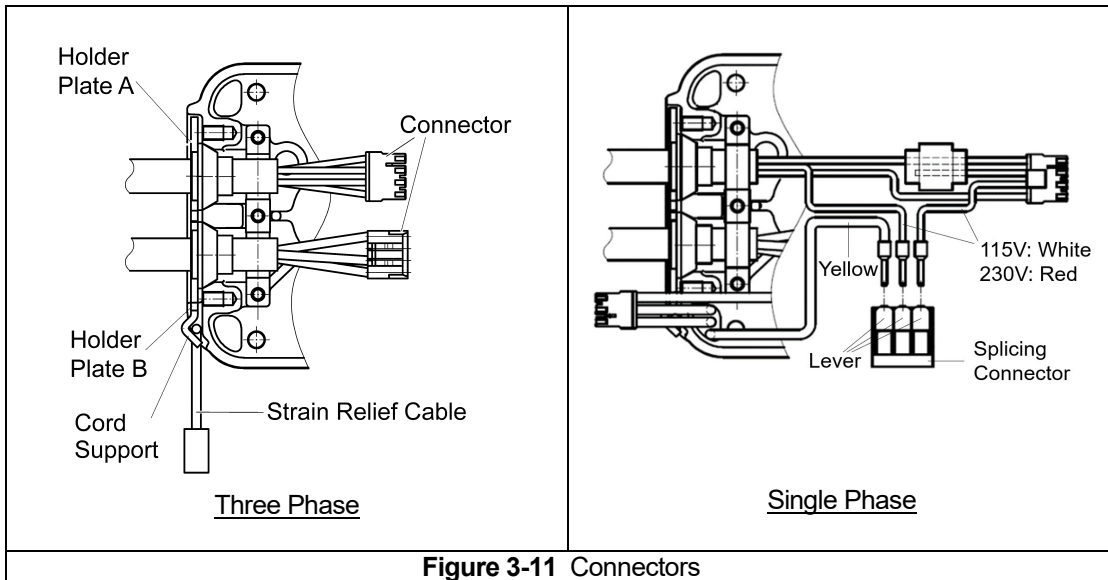

*Tightening torque for the Pan Head Screws: 2.3 N-m (1.7 lb-ft)

3.5.10 Connection to Electrical Power Source - The red, white, and black wires of the Power Supply Cable should be connected to an Electric Power Disconnect Switch or Circuit Breaker. If pendant button depression does not match direction of operation refer to **Section 3.6.15**.

3.5.11 Hoist Current Overload Protection - The hoist's power supply shall be equipped with current overload protection such as fuses or breaker.

- Fuse Capacity - The fuse should be selected for 110% to 120% of total listed full load amperage and should be dual element time-delay fuses. Refer to the motor nameplate for the full load amperage draw.
- Breaker Capacity - Check that the rating of the breaker satisfies the specification required by the electric chain hoist.

3-phase

Product Code	Breaker Rating (A)	
	230V class	460V class
EM001S	5	5
EM003L/005C		

Single-phase

Product Code	Breaker Rating (A)	
	115V class	230V class
SEM003L/005C	10	5

3.5.12 **⚠ DANGER** Grounding - An improper or insufficient ground connection creates an electrical shock hazard when touching any part of the hoist or trolley. In the Power Supply Cable the ground wire will be either Green with Yellow stripe or solid Green. It should always be connected to a suitable ground connection. **Do NOT** paint the trolley wheel running surfaces of the beam as this can affect grounding.

3.6 Initial Inspection and Trial Operation

- 3.6.1 **⚠ WARNING** Confirm the adequacy of the rated capacity for all slings, chains, wire ropes and all other lifting attachments before use. Inspect all load suspension members for damage prior to use and replace or repair all damaged parts.
- 3.6.2 **⚠ WARNING** If conducting a multi-hoist lift, user should conduct risk assessment and prepare the hoists with appropriate load monitoring and safety equipment.
- 3.6.3 **⚠ WARNING** Verify and correct all chain irregularities prior to operating the hoist. Refer to **Section 3.2**.
- 3.6.4 **⚠ WARNING** Confirm that there are no obstacles in the route of the hoist and the load.
- 3.6.5 Measure and record the “k” dimension of all hooks on hoist. See **Table 5-5** under **Section 5**.
- 3.6.6 Record the hoist’s Code, Lot and Serial Number (from the name plate on the hoist; see **Section 9**) in the space provided on the cover of this manual.
- 3.6.7 Ensure that the hoist is properly installed to either a fixed point, or trolley, whichever applies.
- 3.6.8 If hoist is installed on a trolley, ensure that
- Trolley is properly installed on the beam.
 - Stops for the trolley are correctly positioned and securely installed on the beam. (See Harrington Hoists Manual Trolley TF2/TS2 Owner’s Manual)
 - The running surface of Traverse Rail is base metal and not painted or oiled. There is no obstacle for the trolley to travel. The Traverse Rail is set to a level.
 - Power Cable is fixed to the Cable Support
- 3.6.9 Ensure that all nuts, bolts and split pins (cotter pins) are sufficiently fastened.
- 3.6.10 Pull down on the Pendant and ensure that the Strain Relief Cable takes the force, not the Pendant Cord.
- 3.6.11 **⚠ CAUTION** All hoists are voltage specific.
- 3.6.12 Grounding wire (Class D) is connected securely.
- 3.6.13 **⚠ CAUTION** Check supply voltage and phase before everyday use. If the voltage varies more than 10% of the rated voltage, electrical devices may not function normally.
- 3.6.14 Confirm proper operation.
- Before operating read and become familiar with **Section 4 – Operation**.
 - Before operating ensure that the hoist (and trolley) meets the Inspection, Testing and Maintenance requirements of ANSI/ASME B30.16.
 - Before operating ensure that nothing will interfere with the full range of the hoist’s (and trolley’s) operation.
- 3.6.15 Ensure that the direction on the pendant control matches the direction of the hoist (UP raises the hoist load chain/hook; DOWN lowers the hoist load chain/hook). If the hoist does not operate correctly, shut off and lockout /tagout the main power source to the hoist. Disconnect and correct control circuit (Note: this hoist has reverse phase protection; switching phases of power supply should not be needed).

4.0 Operation

4.1 Introduction

DANGER

DO NOT WALK UNDER A SUSPENDED LOAD

WARNING

HOIST OPERATORS SHALL BE REQUIRED TO READ THE OPERATION SECTION OF THIS MANUAL, THE WARNINGS CONTAINED IN THIS MANUAL, INSTRUCTION AND WARNING LABELS ON THE HOIST OR LIFTING SYSTEM, AND THE OPERATION SECTIONS OF ANSI/ASME B30.16 and ANSI/ASME B30.10. THE OPERATOR SHALL ALSO BE REQUIRED TO BE FAMILIAR WITH THE HOIST AND HOIST CONTROLS BEFORE BEING AUTHORIZED TO OPERATE THE HOIST OR LIFTING SYSTEM.

HOIST OPERATORS SHOULD BE TRAINED IN PROPER RIGGING PROCEDURES FOR THE ATTACHMENT OF LOADS TO THE HOIST HOOK.

HOIST OPERATORS SHOULD BE TRAINED TO BE AWARE OF POTENTIAL MALFUNCTIONS OF THE EQUIPMENT THAT REQUIRE ADJUSTMENT OR REPAIR, AND TO BE INSTRUCTED TO STOP OPERATION IF SUCH MALFUNCTIONS OCCUR, AND TO IMMEDIATELY ADVISE THEIR SUPERVISOR SO CORRECTIVE ACTION CAN BE TAKEN.

HOIST OPERATORS SHOULD HAVE NORMAL DEPTH PERCEPTION, FIELD OF VISION, REACTION TIME, MANUAL DEXTERITY, AND COORDINATION.

HOIST OPERATORS SHOULD **NOT** HAVE A HISTORY OF OR BE PRONE TO SEIZURES, LOSS OF PHYSICAL CONTROL, PHYSICAL DEFECTS, OR EMOTIONAL INSTABILITY THAT COULD RESULT IN ACTIONS OF THE OPERATOR BEING A HAZARD TO THE OPERATOR OR TO OTHERS.

HOIST OPERATORS SHOULD **NOT** OPERATE A HOIST OR LIFTING SYSTEM WHEN UNDER THE INFLUENCE OF ALCOHOL, DRUGS, OR MEDICATION.

OVERHEAD HOISTS ARE INTENDED ONLY FOR VERTICAL LIFTING SERVICE OF FREELY SUSPENDED UNGUIDED LOADS. **DO NOT** USE HOIST FOR LOADS THAT ARE NOT LIFTED VERTICALLY, LOADS THAT ARE NOT FREELY SUSPENDED, OR LOADS THAT ARE GUIDED.

NOTICE

- Read ANSI/ASME B30.16 and ANSI/ASME B30.10.
- Read the hoist manufacturer's Operating and Maintenance Instructions.
- Read all labels attached to equipment.

The operation of an overhead hoist involves more than activating the hoist's controls. Per the ANSI/ASME B30 standards, the use of an overhead hoist is subject to certain hazards that cannot be mitigated by engineered features, but only by the exercise of intelligence, care, common sense, and experience in anticipating the effects and results of activating the hoist's controls. Use this guidance in conjunction with other warnings, cautions, and notices in this manual to govern the operation and use of your overhead hoist.

4.2 Shall's and Shall Not's for Operation

⚠ WARNING

Improper operation of a hoist can create a potentially hazardous situation which, if not avoided, could result in death or serious injury, and substantial property damage. To avoid such a potentially hazardous situation **THE OPERATOR SHALL:**

- **NOT** operate a damaged, malfunctioning or unusually performing hoist.
- **NOT** operate a hoist until you have thoroughly read and understood Manufacturer's Operating and Maintenance Instructions or Manuals.
- **NOT** operate a hoist that has been modified without the manufacturer's approval or without certification that it is in conformity with ANSI/ASME B30 volumes.
- **NOT** lift more than rated load for the hoist.
- **NOT** use hoist with twisted, kinked, damaged, or worn load chain.
- **NOT** use the hoist to lift, support, or transport people.
- **NOT** lift loads over people.
- **NOT** operate a hoist unless all people are and remain clear of the supported load.
- **NOT** operate unless load is centered under hoist.
- **NOT** attempt to lengthen the load chain or repair damaged load chain.
- **NOT** operate hoist when it is restricted from forming a straight line from hook to support in the direction of loading.
- **NOT** lift the load at an angle (side pull).
- **NOT** use load chain as a sling or wrap load chain around load.
- **NOT** apply the load to the tip of the hook or to the hook latch.
- **NOT** apply load unless the load chain is properly seated in its grooves.
- **NOT** apply load if bearing prevents equal loading on all load-supporting chain.
- **NOT** operate beyond the limits of the load chain travel.
- **NOT** leave load supported by the hoist unattended unless specific precautions have been taken.
- **NOT** allow the load chain or hook to be used as an electrical or welding ground.
- **NOT** allow the load chain or hook to be touched by a live welding electrode.
- **NOT** remove or obscure the warnings on the hoist.
- **NOT** operate a hoist on which the safety placards or decals are missing or illegible.
- **NOT** operate a hoist unless it has been securely attached to a suitable support.
- **NOT** operate a hoist unless load slings or other approved single attachments are properly sized and seated in the hook saddle.

- **NOT** use the hoist in such a way that could result in shock or impact loads being applied to the hoist.
- **NOT** use the Emergency Stop Button for ordinary stop operation.
- **NOT** lift a load with the no-load side of the Load Chain.
- **NOT** use the electric chain hoist when the Electronic Overload Limiter and/or the Friction Clutch are activated. Lower and reset load to rated capacity.
- **NOT** swing the lifted load.
- **NOT** carry out reversing operation while lifting/lowering a load. When reversing the motion, stop the electric chain hoist and then reverse the motion.
- **NOT** carry out excessively frequent inching (over 5 times).
- **NOT** cause the load to come into contact with the Load Chain.
- **NOT** carry out the welding or cutting work on a lifted load.
- **NOT** repair or disassemble a lifted load.
- **NOT** hit the Chain Container with a load or slinging devices.
- **NOT** use limit switches as routine operating stops. They are emergency devices only.
- **NOT** overwind the hoist in lifting or lowering direction.
- **NOT** use the hoist in applications that subject the hoist to shock load.
- **NOT** hit the trolley to the rail end stopper.
- Take up slack carefully – make sure load is balanced and load-holding action is secure before continuing.
- Make sure hoist limit switches function properly.
- Shut down a hoist that malfunctions or performs unusually and report such malfunction.
- Warn personnel before lifting or moving a load.
- Protect the hoist's load chain from weld splatter or other damaging contaminants.
- Be familiar with operating controls, procedures, and warnings.
- Warn personnel of an approaching load.
- Stop the lifting work immediately and lower the load when the limit switch (over winding prevention device) is operated.
- Ensure chain stoppers are in place.
- Make sure the load is distributed evenly and the load on each hoist is within the hoists rated capacity for multi-point/simultaneous operation. If one hoist stops due to activation of the E-OLL, stop all hoist operation and reset the affected hoist (see **section 4.3.3**). Level the load and confirm the load distribution and weight per hoist is within operating limits before continuing the simultaneous lift.
- Make sure angle formed by two slings must be 120 degrees or less.
- Make sure the chain is not tangled before using the hoist.
- Make sure the hoist and its load are clear from all obstructions.

CAUTION

Improper operation of a hoist can create a potentially hazardous situation which, if not avoided, could result in minor or moderate injury, or property damage. To avoid such a potentially hazardous situation **THE OPERATOR SHALL:**

- Maintain a firm footing or be otherwise secured when operating the hoist.
- Check brake function by tensioning the hoist prior to each lift operation.
- Use hook latches. Latches are to retain slings, chains, etc. under slack conditions only.
- Make sure the hook latches are closed and not supporting any parts of the load.
- Avoid swinging the load or hook.
- Make sure hook travel is in the same direction as shown on controls.
- Inspect the hoist regularly, replace damaged or worn parts, and keep appropriate records of maintenance.
- Use the hoist manufacturer's recommended parts when repairing the unit.
- Lubricate load chain per hoist manufacturer's recommendations.
- Wait at least 5 seconds to turn on the power after shutting off the power for reenergizing.
- **NOT** use the hoist load limiting or warning device to measure load.
- **NOT** allow your attention to be diverted from operating the hoist.
- **NOT** allow the hoist to be subjected to sharp contact with other hoists, structures, or objects through misuse.
- **NOT** adjust or repair the hoist unless qualified to perform such adjustments or repairs.

4.3 Hoist Controls

4.3.1 Emergency Stop Button – Press the Emergency Stop Button to perform an emergency stop and lock-out of hoist motion controls or to reset an error that SSR detected (see **Figure 4-1**). Turn the Emergency Stop Button clockwise to unlock the controls and allow hoist operation.

4.3.2 Pendant Control – When using the pendant control, depress the UP button to raise the hoist load chain/hook or the DOWN button to lower the hoist load chain/hook as shown in **Figure 4-1**. To stop motion, release the buttons.

4.3.3 Resetting the Electronic Overload Limiter (E-OLL) - When the E-OLL is activated during lifting, hold down the DOWN Button for 2 seconds or more or press and release the Emergency Stop Button. When the E-OLL is activated during lowering, hold down the UP Button for 2 seconds or more or more or press and release the Emergency Stop Button.

4.3.4 **⚠ CAUTION** Make sure the motor completely stops before reversing direction.

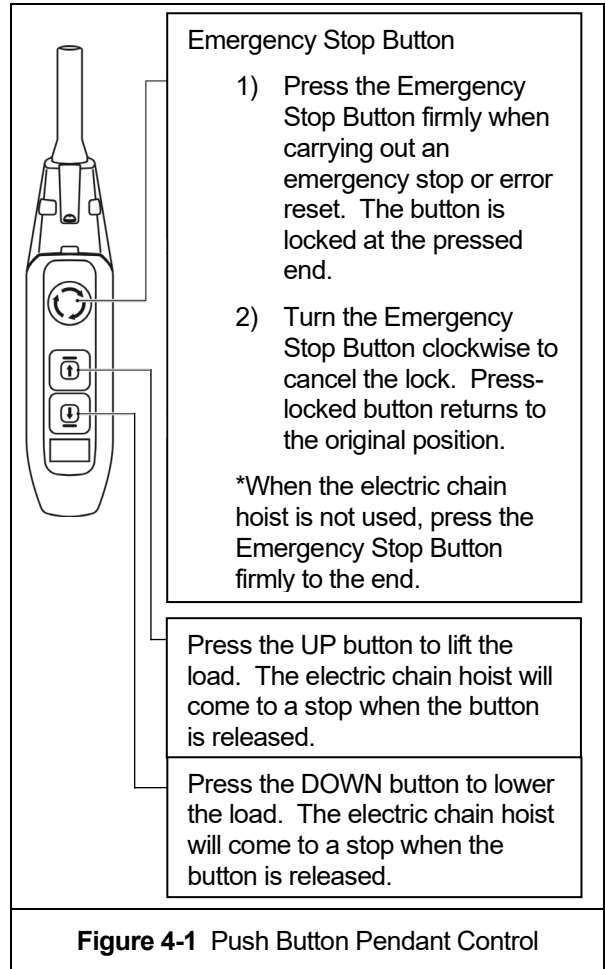

5.0 Inspection

5.1 General

The inspection, maintenance and troubleshooting procedure herein is based on ANSI/ASME B30.16. The following definitions pertain to the inspection, maintenance and troubleshooting procedure below.

- **Designated Person** – a person selected or assigned as being competent to perform the specific duties to which he/she is assigned.
- **Qualified Person** – a person who, by possession of a recognized degree or certificate of professional standing, or who, by extensive knowledge, training, and experience, has successfully demonstrated the ability to solve or resolve problems relating to the subject matter and work.
- **Normal Service** – that distributed service which involves operation with randomly distributed loads within the rated load limit, or uniform loads less than 65% of rated load for not more than 25% of the time.
- **Heavy Service** – that service which involves operation within the rated load limit which exceeds normal service.
- **Severe Service** – that service which involves normal or heavy service with abnormal operating conditions.

WARNING

HAZARDOUS VOLTAGES ARE PRESENT IN THE HOIST AND IN CONNECTIONS BETWEEN COMPONENTS.

Before performing ANY maintenance on the equipment, de-energize the supply of electricity to the equipment, and lock and tag the supply device in the de-energized position. Refer to ANSI Z244.1, "Personnel Protection – Lockout/Tagout of Energy Sources."

To avoid a shock hazard, **DO NOT** perform **ANY** mechanical or electrical maintenance on the hoist within 5 minutes of de-energizing (disconnecting) the hoist. This time allows the internal capacitor to safely discharge.

Personnel assigned to inspect, maintain, and troubleshoot this equipment shall meet the definition of **Designated Person**.

Improper inspection of a hoist can create a potentially hazardous situation which, if not avoided, could result in death or serious injury, and substantial property damage. To avoid such a potentially hazardous situation **THE DESIGNATED PERSON SHALL:**

- **NOT** use a part exceeding its service limit or a part other than genuine part for Harrington/KITO electric chain hoist
- **NOT** adjust or disassemble the Electromagnetic Brake or the Friction Clutch (Rotor Assembly).
- **NOT** carry out the inspection of the electric chain hoist with a lifted load.
- **NOT** use the electric chain hoist when an abnormality was observed during the inspection, and contact with maintenance engineers or Harrington/KITO for repair.
- Avoid places with fire or sparks when using lubricants such as grease.
- Control hazardous energy in accordance with ANSI/ASSP Z244.1, "The Control of Hazardous Energy Lockout, Tagout and Alternative Methods" and OSHA Regulations.
- Perform the functional check and make sure that the electric chain hoist operates correctly after completion of the inspection (frequent, periodic).
- Be sure to pay attention to the change of the operating sound of the electric chain hoist and trolley. The change of operating sound is an important factor to judge the failure.

CAUTION

Improper inspection of a hoist can create a potentially hazardous situation which, if not avoided, could result in minor or moderate injury, or property damage. To avoid such a potentially hazardous situation, **THE DESIGNATED PERSON SHALL:**

- Wear protection equipment such as protection goggles and gloves. Otherwise, it may result in an injury due to spilled liquids or sharp edges.
- Pay attention to work method, work procedure and work posture. If the product or the part is heavy, be cautious of pinch point or injury from lifting. Be especially careful if work is conducted on a scaffold or ladder.
- Wear helmet and proper fall protection when working at heights. Otherwise, it may result in injury or a fall accident.
- Clean up any liquids on product or floor. Otherwise, it may result in injury due to dropping the product or slipping.
- Keep the work area clean when disassembling the product. Assembling or mixing parts other than genuine part may result in the damage of the product or the accident due to defective operation.

NOTICE

- When performing the frequent inspection, carry out the preoperational inspection at the same time.
- When performing the periodic inspection, carry out the frequent inspection at the same time.
- When detecting any abnormality during inspection due to erroneous use, instruct the operator and user for correct use of the electric chain hoist.
e.g. (1) Damage on the Chain Guide A caused by contact with chain indicates side pulling
(2) Damage or deformation of the Cushion Rubber indicates misuse of hoist's limit switch

5.2 Inspection Classification

- 5.2.1 Initial Inspection – prior to initial use, all new, altered, or modified hoists shall be inspected by a designated person to ensure compliance with the applicable provisions of this manual.
- 5.2.2 Inspection Classification – the inspection procedure for hoists in regular service is divided into three general classifications based upon the intervals at which inspection should be performed. The intervals in turn are dependent upon the nature of the critical components of the hoist and the degree of their exposure to wear, deterioration, or malfunction. The three general classifications are herein designated as PREOPERATIONAL, FREQUENT and PERIODIC, with respective intervals between inspections as defined below.
- 5.2.3 Initial Inspection – prior to initial use, all new, altered, or modified hoists shall be inspected per the Frequent Inspection criteria in **Table 5-2**. The inspections for altered or modified hoists can be limited to the items related to the replaced parts.
- 5.2.4 PREOPERATIONAL Inspection – Visual inspection performed before the first use of each shift with records not required.
- 5.2.5 FREQUENT Inspection – visual examinations by the operator or other designated personnel with intervals per the following criteria:
- Normal service – monthly
 - Heavy service – weekly
 - Severe service – daily
 - Special or infrequent service – as recommended by a qualified person before and after each occurrence
- 5.2.6 PERIODIC Inspection – visual inspection by a designated person with intervals per the following criteria:
- Normal service – yearly
 - Heavy service – semiannually
 - Severe service – quarterly
 - Special or infrequent service – as recommended by a qualified person before the first such occurrence and as directed by the qualified person for any subsequent occurrences.

5.3 Preoperational Inspection

5.3.1 Visual inspections shall be made before the first use of each shift with records not required.

Table 5-1 Preoperational Inspection
All functional operating and control mechanisms for proper operation and adjustment, maladjustment and unusual sounds.
Hooks and latches in accordance with ANSI/ASME B30.10
Load chain in accordance with Section 5.8
Over-travel restraint for proper attachment.
Hoist body and lever for deformation, cracks and /or other damage.
Hoist support or trolley, if used, for damage.

5.4 Frequent Inspection

5.4.1 Inspections should be made on a FREQUENT basis in accordance with **Table 5-2**, "Frequent Inspection." Included in these FREQUENT Inspections are observations made during operation for any defects or damage that might appear between Periodic Inspections. Evaluation and resolution of the results of FREQUENT Inspections shall be made by a designated person such that the hoist is maintained in safe working condition.

Table 5-2 Frequent Inspection
All functional operating mechanisms for proper operation and adjustment, maladjustment and unusual sounds.
Operation of limit switch, pendant controls, and associated components
Hoist braking system for proper operation
Hooks in accordance with ANSI/ASME B30.10
Hook latch operation
Load chain in accordance with Section 5.8
Load chain reeving for compliance with Section 3.2 and 6.5

WARNING

HAZARDOUS VOLTAGES ARE PRESENT IN THE HOIST AND IN CONNECTIONS BETWEEN COMPONENTS.

Before performing ANY maintenance on the equipment, de-energize the supply of electricity to the equipment, and lock and tag the supply device in the de-energized position. Refer to ANSI Z244.1, "Personnel Protection – Lockout/Tagout of Energy Sources."

To avoid a shock hazard, **DO NOT** perform **ANY** mechanical or electrical maintenance on the hoist within 5 minutes of de-energizing (disconnecting) the hoist. This time allows the internal capacitor to safely discharge.

Personnel assigned to inspect, maintain, and troubleshoot this equipment shall meet the definition of **Designated Person**.

Improper inspection of a hoist can create a potentially hazardous situation which, if not avoided, could result in death or serious injury, and substantial property damage. To avoid such a potentially hazardous situation **THE DESIGNATED PERSON SHALL:**

- Perform the functional check and make sure that the electric chain hoist operates correctly after completion of the periodic inspection.
- **NOT** touch the controller cover as it becomes hot during operation.
- **NOT** touch the controller cover until about 30 minutes elapsed after the stop of operation.
- **NOT** change the connection of the SSR board nor adjust/change any of its switches, dials or jumper pins.
- **NOT** carry out withstand voltage test of a circuit while the SSR is connected.
- **NOT** turn off the power while operating.

Failure to comply with these instructions may result in death or serious injury and the damage of the SSR.

5.5 Periodic Inspection

- 5.5.1 Inspections should be made on a PERIODIC basis in accordance with **Table 5-3**, "Periodic Inspection." Evaluation and resolution of the results of PERIODIC Inspections shall be made by a designated person such that the hoist is maintained in safe working condition.
- 5.5.2 For inspections where load suspension parts of the hoist are disassembled, a load test per ANSI/ASME B30.16 must be performed on the hoist after it is re-assembled and prior to its return to service.

Table 5-3 Periodic Inspection

Requirements of frequent inspection.
Evidence of loose bolts, nuts, or rivets.
Evidence of worn, corroded, cracked, or distorted parts such as load blocks, suspension housing, chain attachments, clevises, yokes, suspension bolts, shafts, gears, bearings, pins, and rollers.
Evidence of damage to hook retaining nuts or collars and pins, and welds or rivets used to secure the retaining members.
Evidence of damage or excessive wear of load and idler sheaves.
Evidence of excessive wear on motor or load brake.

Table 5-3 Periodic Inspection
Electrical apparatus for signs of pitting or any deterioration of visible controller contacts.
Evidence of damage of supporting structure or trolley, if used.
Function labels on pendant control stations for legibility.
Warning label properly attached to the hoist and legible (see Section 1.2).
End connections of load chain.

WARNING

HAZARDOUS VOLTAGES ARE PRESENT IN THE HOIST AND IN CONNECTIONS BETWEEN COMPONENTS.

Before performing ANY maintenance on the equipment, de-energize the supply of electricity to the equipment, and lock and tag the supply device in the de-energized position. Refer to ANSI Z244.1, "Personnel Protection – Lockout/Tagout of Energy Sources."

To avoid a shock hazard, **DO NOT** perform **ANY** mechanical or electrical maintenance on the hoist within 5 minutes of de-energizing (disconnecting) the hoist. This time allows the internal capacitor to safely discharge.

Personnel assigned to inspect, maintain, and troubleshoot this equipment shall meet the definition of **Designated Person**.

Improper inspection of a hoist can create a potentially hazardous situation which, if not avoided, could result in death or serious injury, and substantial property damage. To avoid such a potentially hazardous situation **THE DESIGNATED PERSON SHALL:**

- Put the electric chain hoist on the floor or work bench when inspecting the electric chain hoist.
- Perform the functional check and make sure that the electric chain hoist operates correctly after completion of the periodic inspection.
- Wear insulating gloves when measuring voltage.
- Turn off the power when measuring (except voltage measurement) the electric characteristics (insulation resistance).
- **NOT** touch the controller cover as it becomes hot during operation.
- **NOT** touch the controller cover until about 30 minutes elapsed after the stop of operation.
- **NOT** change the connection of the SSR board nor adjust/change any of its switches and jumper pins.
- **NOT** carry out withstand voltage test of a circuit while the SSR is connected.
- **NOT** turn off the power while operating.

Failure to comply with these instructions may result in death or serious injury and the damage of the SSR.

5.6 Occasionally Used Hoists

5.6.1 Hoists that are used infrequently shall be inspected as follows prior to placing in service:

- Hoist Idle More Than 1 Month, Less Than 1 Year: Inspect per FREQUENT Inspection criteria in **Section 5.4**.
- Hoist Idle More Than 1 Year: Inspect per PERIODIC Inspection criteria in **Section 5.5**.

5.7 Inspection Records

- 5.7.1 Dated inspection reports and records should be maintained at time intervals corresponding to those that apply for the hoist's PERIODIC interval per **Section 5.2.6**. These records should be stored where they are available to personnel involved with the inspection, maintenance, or operation of the hoist.
- 5.7.2 A long range chain inspection program should be established and should include records of examination of chains removed from service so a relationship can be established between visual observation and actual condition of the chain.

5.8 Inspection Methods and Criteria

- 5.8.1 This section covers the inspection of specific items. The list of items in this section is based on those listed in ANSI/ASME B30.16 for the Frequent and Periodic Inspection. In accordance with ANSI/ASME B30.16, these inspections are not intended to involve disassembly of the hoist. Rather, disassembly for further inspection would be required if frequent or periodic inspection results so indicate. Such disassembly and further inspection should only be performed by a designated person trained in the disassembly and re-assembly of the hoist.

Item	Method	Criteria	Action
Functional operating mechanisms.	Visual, Auditory	Mechanisms should be properly adjusted and should not produce unusual sounds when operated.	Repair or replace as required.
Upper Limit Switch	Function	Proper operation. Actuation of limit switch should stop hoist.	Repair or replace as required.
Limit Spring	Visual	No deformation, damage, wear, or stain. Refer to Figure 5-1 .	Replace
Braking System Operation	Function	Braking distance with rated capacity shall not exceed 1% of the lifting speed (approximately two chain links).	Repair or replace as required.
Hooks - Surface Condition	Visual	Should be free of significant rust, weld splatter, deep nicks, or gouges.	Replace.
Hooks - Fretting wear	Measure	The "u" and "t" dimensions should not be less than discard value listed in Table 5-5 .	Replace.
Hooks - Stretch	Measure	The "k" dimension shall not be greater than 1.05 times that measured and recorded at the time of purchase (See Section 3.6.5). If recorded "k" values are not available for hooks when new, use nominal "k" values from Table 5-5 .	Replace.

Table 5-4 Hoist Inspection Methods and Criteria

Item	Method	Criteria	Action
Hooks - Bent Shank or Neck	Visual	Shank and neck portions of hook should be free of deformations or gouges.	Replace.
Hooks - Swivel Bearing	Visual, Function	Bearing parts and surfaces should not show significant wear, and should be free of dirt, grime, and deformations. Hook should rotate freely with no roughness.	Clean/lubricate or replace as required.
Hooks and Suspender - Hole	Visual	Should be free of significant rust, weld splatter, nicks, and gouges. Holes should not be elongated. The difference between dimensions “a” (vertical) and “b” (horizontal) must be within .020” (0.5mm), refer to Figure 5-3 . Fasteners should not be loose, and there should be no gap between mating parts.	Measure, tighten, or replace as required.
Hooks - Top Pin	Visual	No apparent deformation or bent. The diameter (D) of the Top Pin does not fall under the working limit value. Refer to Table 5-9 .	Replace.
Hooks – Pin Stopper	Visual	Should not have any deformation, abrasion, or damage. Refer to Figure 5-2 .	Replace.
Hooks - Idle Sheave and Axle (Bottom Hook on Double Fall Hoist)	Visual, Function	Pockets of Idle Sheave should be free of significant wear. Idle Sheave surfaces should be free of nicks, gouges, dirt, and grime. Bearing parts and surfaces of Idle Sheave and Axle should not show significant wear. Idle Sheave should rotate freely with no roughness or significant free play. Wall thickness shall be less than 0.175” (4 mm) to match the load sheave. Refer to Table 5-12 .	Clean/lubricate or replace as required.
Hooks - Hook Latches	Visual, Function	Latch should not be deformed. Attachment of latch to hook should not be loose. Latch spring should not be missing and should not be weak. Latch movement should not be stiff - when depressed and released latch should snap smartly to its closed position.	Replace.
Load Chain - Surface Condition	Visual	Should be free of rust, nicks, gouges, dents, and weld splatter. Links should not be deformed and should not show signs of abrasion. Surfaces where links bear on one another should be free of significant wear. NOTICE When the wear of the Load Chain is observed, be sure to check the wear of the Load Sheave as well.	Replace.

Table 5-4 Hoist Inspection Methods and Criteria

Item	Method	Criteria	Action
Load Chain - Pitch and Wire Diameter	Measure	<p>The "P" dimension shall not be greater than maximum value listed in Table 5-7. The "d" dimension shall not be less than minimum value listed in Table 5-7.</p> <p>NOTICE Check the engaging point of the Load Sheave carefully.</p>	Replace. Inspect Load Sheave (and Idle Sheave for double fall hoist).
Load Chain - Lubrication	Visual, Auditory	Entire surface of each chain link should be coated with lubricant and should be free of dirt and grime. Chain should not emit cracking noise when hoisting a load.	Clean/lubricate (see Section 6.1).
Load Chain - Reeving	Visual	Chain should be reeved properly through Load Sheave (and Idle Sheave for double fall hoist) - refer to Section 6.5 . Chain, Chain Springs, Cushion Rubbers, Striker Plates, and Stoppers should be installed properly - refer to Section 3.2 .	Reeve/Install chain properly.
Load Chain – Connection Yoke Chain Pin (Double Reeved Hoists Only)	Measure	The Connection Yoke Chain Pin should not have and apparent deformation. The "d" dimension shall not be less than the discard value listed in Table 5-8 .	Replace.
Cushion Rubber and Stopper	Visual	Should be free of significant deformation. The stopper must be attached securely at the third horizontal link from the no load end of the Load Chain.	Replace.
Chain Guide	Visual	<p>Chain Guide should be free of significant wear. Chain Guide surfaces should be free of deformation by nicks, gouges, and abrasion. The "b" dimension shall be less than .276" (7.0 mm). Refer to Table 5-10. No wear due to contact from Load Chain.</p> <p>CAUTION Damage due to chain contact is an indication of improper use such as side pulling. If the wear is observed on the Chain Guide, the Load Chain may be worn as well.</p>	Replace.
Chain Container	Visual	Container should not be damaged, torn, worn or deformed. Brackets should not be deformed or missing. No foreign matter should be inside the container. The Lift value of the load chain shall not exceed the maximum published on the container (see Figure 3-4).	Replace.

Table 5-4 Hoist Inspection Methods and Criteria

Item	Method	Criteria	Action
Chain Container bracket	Measure, Visual	No damage, wear, or deformation. For the specifications of the canvas chain container.	Replace.
Grease Leak	Visual	No leak of gear grease from the packing.	Replace.
Housing and Mechanical Components	Visual, Auditory, Vibration, Function	Hoist components including load blocks, suspension housing, chain attachments, clevises, yokes, suspension bolts, shafts, gears, bearings, pins and rollers should be free of cracks, distortion, significant wear and corrosion. Evidence of same can be detected visually or via detection of unusual sounds or vibration during operation.	Replace.
Gaskets and Sealing Enclosures	Visual	Gaskets and sealing enclosures must be in good condition and installed properly to preserve the IP rating of the hoist.	Replace.
Bolts, Nuts and Rivets	Visual, Check with Proper Tool	Bolts, nuts, and rivets should not be loose.	Tighten or replace as required.
Electromagnetic Brake Assembly	Measure, Visual, Calculation	<p>The electromagnetic motor brake gap is directly related to brake disk wear. As the disk wears, the brake gap will increase. The brake gap/wear dimension shall not be more than discard value listed in Table 5-11. Bolts and screws should not be loose. No flaw and damage. In case there is accumulated worn powder, remove it around the brake and on the control board by compressed air, etc. The number of starts shall be less than one million times.</p> <p>⚠ WARNING When inspecting the Brake and replacing a part, the worn powder of a friction material is scattered. Put on a protective gear such as a dust-proof mask, goggles and gloves.</p>	<p>Tighten bolts and screws as required or replace Brake Assembly. Note: Do NOT attempt to adjust or disassemble the Brake Assembly.</p> <p>Replace at one million times.</p>
SSR	Visual, Function	There should be no fault codes (refer to Section 7.1.2).	Replace as needed.
Single-phase Starting Capacitor	Calculation	The number of starts shall be less than one million times.	Replace at one million times.

Table 5-4 Hoist Inspection Methods and Criteria

Item	Method	Criteria	Action
Load Sheave	Visual	Pockets of Load Sheave should be free of significant wear. Refer to Table 5-12 for Load Sheave wear dimensions.	Replace.
Pendant - Housing	Visual	Pendant housing should be free of cracks and mating surfaces of parts should seal without gaps.	Replace.
Pendant - Wiring	Visual	Wire connections to switches in pendant should not be loose or damaged.	Tighten or repair
Pendant - Switches	Function	No damage, deformation, or loosened bolt. Depressing and releasing push-buttons should make and break contacts in switch contact block and result in corresponding electrical continuity or open circuit. Push-buttons should be interlocked either electrically or mechanically to prevent simultaneous energization of circuits for opposing motions (e.g. up and down).	Repair or replace as necessary.
Pendant - Cord	Visual, Electrical Continuity	Surface of cord should be free from nicks, gouges, and abrasions. Each conductor in cord should have 100% electrical continuity even when cord is flexed back-and-forth. Pendant Cord Strain Relief Cable should absorb the entire load associated with forces applied to the pendant. Push Button Switch Cord is securely connected with the cable clamp (see Figure 3-10).	Properly secure the Strain Relief cable and the Pendant Cord to the hoist body or replace as necessary
Pendant - Labels	Visual	Labels denoting functions should be legible.	Replace.
Power Cable	Visual	Surface of cord should be free from nicks, gouges, and abrasions. Length of cable should be sufficient for application. It should be connected securely with the cable clamp (see Figure 3-10).	Properly secure the Power Cord to the hoist body or replace as necessary.
Warning Tags and Labels	Visual	Warning Tags and Labels should be affixed to the hoist (see Section 1.2) and they should be legible.	Replace.
Hoist Capacity Label	Visual	The label that indicates the capacity of the hoist should be legible and securely attached to the hoist.	Replace.
Nameplates	Visual	The nameplates that indicate the hoist model, speed and motor data should be legible and securely attached to the hoist.	Replace.

Table 5-4 Hoist Inspection Methods and Criteria

Item	Method	Criteria	Action
Abnormal noise	Operate the hoist with no load and listen for abnormal noise of gearing, motor and Load Chain	Hoist should not emit popping sounds. Motor should be free of howling noises and free from scraping sounds of the Brake. Hoist should not have abnormal noises. No popping sound from the Load Chain NOTICE Sound is an important check point. Always listen to the noise of the electric chain hoist.	Replace.
Supply Voltage	Measure the voltage with a circuit tester.	The supply voltage must be within $\pm 10\%$ of the values noted in Table 2-1 when checked with an electrical meter at the SSR board CN4. WARNING Be careful of electric shock when measuring the voltage.	Supply proper voltage.
Grounding Resistance	Measure the (grounding area) with earth-resistance meter.	Class D grounding work (grounding resistance: 100 Ω or less) must be conducted. WARNING Turn off the power when measuring the grounding resistance.	Make a grounding correctly.

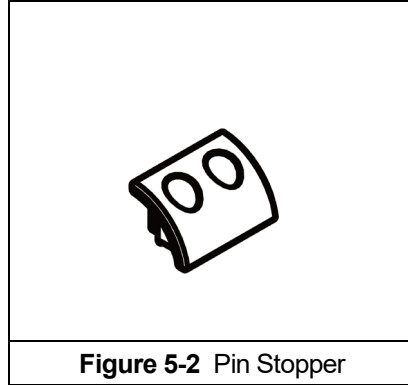
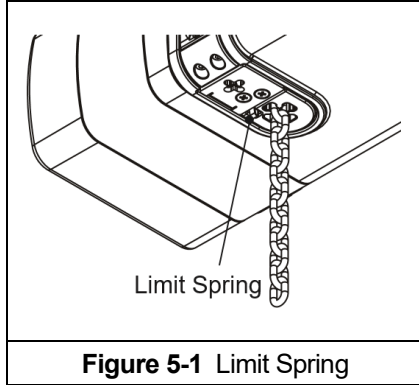

Table 5-5 Top Hook & Bottom Hook Dimensions

"k" Measured When New:
 Top: _____
 Bottom: _____

Nominal "k" Dimension* inch (mm)		"u" Dimension inch (mm)		"t" Dimension inch (mm)	
Standard	Discard	Standard	Discard	Standard	Discard
1.78 (45.1)	1.81 (46.0)	0.709 (18.0)	0.673 (17.1)	0.512 (13.0)	0.484 (12.3)

*These values are nominal since the dimension is not controlled to a tolerance. The "k" dimension should be measured when the hook is new - this becomes a reference measurement. Subsequent measurements are compared to this reference measurement in order to determine hook deformation/stretch. See **Table 5-4, "Hooks - Stretch"**.

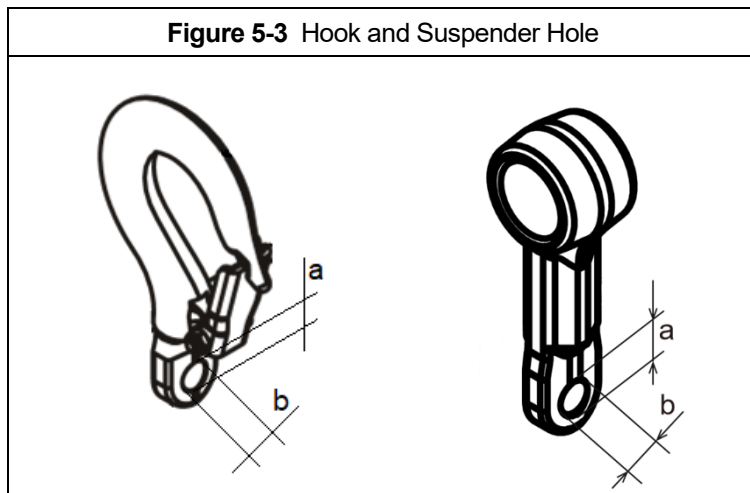

Table 5-7 Chain Wear Dimensions			
			
"P" Dimension inch (mm)		"d" Dimension inch (mm)	
Standard	Discard	Standard	Discard
2.38 (60.5)	2.45 (62.3)	0.157 (4.0)	0.142 (3.6)

Table 5-8 Chain Pin Wear Dimensions	
	
"d" - inch (mm)	
Standard	Discard
0.197 (5.0)	0.185 (4.7)

Table 5-9 Top Pin Wear Dimensions	
	
"D" - inch (mm)	
Standard	Standard
0.394 (10.0)	0.374 (9.5)

Table 5-10 Chain Guide A Wear Dimensions	
	
"b" Dimension - inch (mm)	
Standard	Discard
0.217 (5.5)	0.276 (7.0)

Table 5-11 Motor Brake Wear/Gap Dimensions

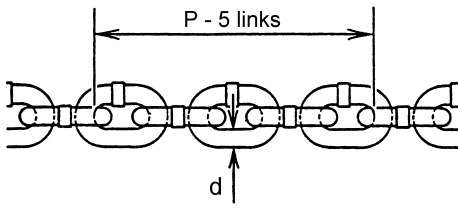

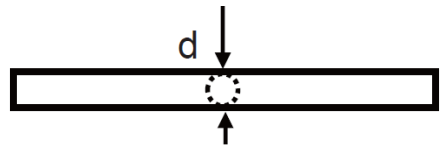
"Gap" Dimension - inch (mm)

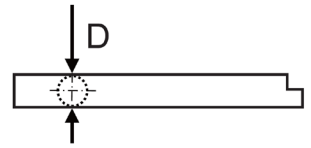
Standard	Discard
0.008 (0.2)	0.016 (0.4)

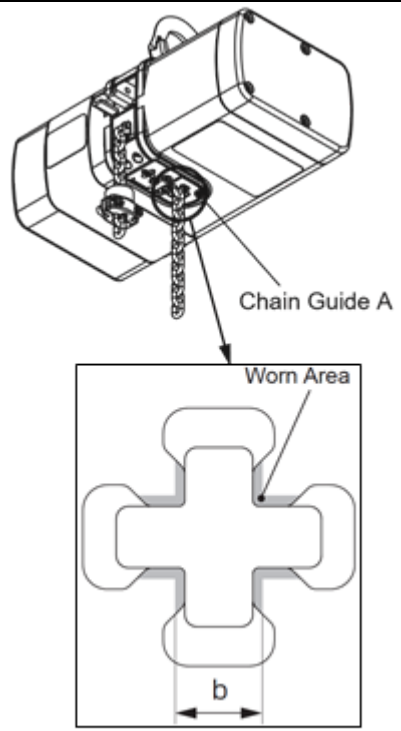
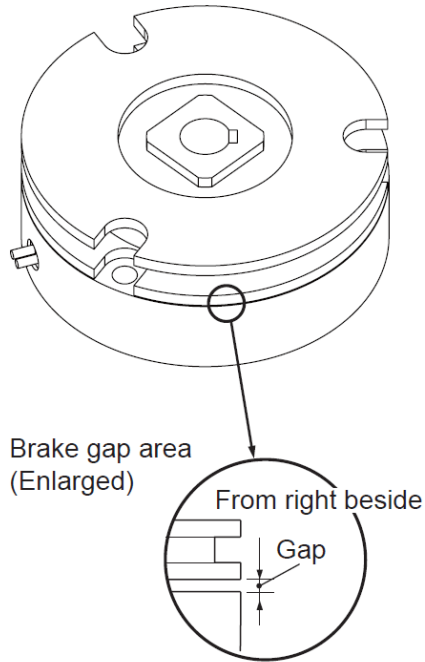
Table 5-12 Load and Idle Sheave Wear Dimensions

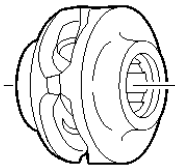

Load Sheave

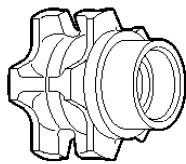

Idle Sheave

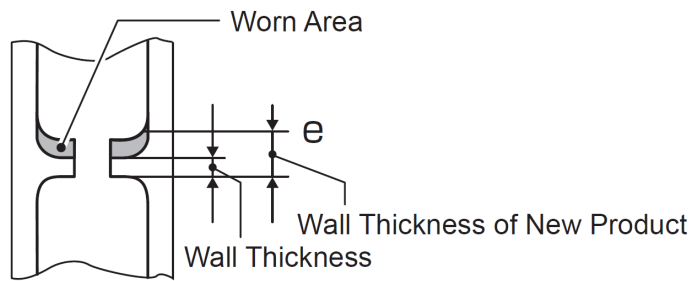

"Thickness" - inch (mm)

Discard

0.175 (4.0)

6.0 Maintenance and Handling

WARNING

HAZARDOUS VOLTAGES ARE PRESENT IN THE HOIST AND IN CONNECTIONS BETWEEN COMPONENTS.

Before performing ANY maintenance on the equipment, de-energize the supply of electricity to the equipment, and lock and tag the supply device in the de-energized position. Refer to ANSI Z244.1, "Personnel Protection – Lockout/Tagout of Energy Sources."

To avoid a shock hazard, **DO NOT** perform **ANY** mechanical or electrical maintenance on the hoist within 5 minutes of de-energizing (disconnecting) the hoist. This time allows the internal capacitor to safely discharge.

Personnel assigned to inspect, maintain, and troubleshoot this equipment shall meet the definition of **Designated Person**.

Improper maintenance of a hoist can create a potentially hazardous situation which, if not avoided, could result in death or serious injury, and substantial property damage. To avoid such a potentially hazardous situation **THE DESIGNATED PERSON SHALL:**

- When any abnormality is observed during the maintenance (repair) of the electric chain hoist, survey the cause by the maintenance engineer and carry out the repair.
- Carry out the repair without lifting a load.
- Perform a load test only after functional check is completed.
- Replace the part exceeding the total operating hours derived from the ISO classification indicated on the electric chain hoist and the load factor even if each component of the electric chain hoist does not exceed the service limit. (See **Section 2.3**)
- **NOT** use a genuine part that is for a different model.

6.1 Lubrication – Load Chain, Hooks and Suspension

6.1.1 Load Chain

- For longer life, the load chain should be lubricated.
- The load chain lubrication should be accomplished after cleaning the load chain with an acid free cleaning solution.
- Apply Harrington Hoist, Inc. lubricating grease (Part No. ER2CS1951) or an equivalent to industrial general lithium grease, NLGI No. 0, to the bearing surfaces of the load chain links as indicated by the shaded areas in **Figure 6-1**. Also apply the grease to the areas of the load chain (shaded areas in **Figure 6-1**) that contact the load sheave. Ensure that the grease is applied to the contact areas in the load sheave pockets.
- Machine or gear oil (grade ISO VG 46 or 68 oil or equivalent) may be used as an alternative lubricant but must be applied more frequently.

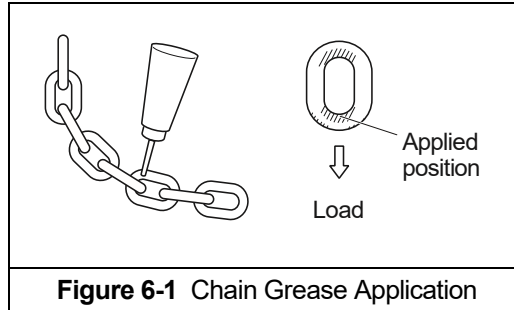

Figure 6-1 Chain Grease Application

- The chain should be lubricated every 3 months (more frequently for heavier usage or severe conditions).
- For dusty environments, it is acceptable to substitute a dry lubricant.

6.1.2 Hooks and Suspension Components:

- Hooks - Bearings should be cleaned and lubricated at least once per year for normal usage. Clean and lubricate more frequently for heavier usage or severe conditions. The grease of the needle bearing for the idle sheave should be replaced every 400 hours (Operating Time per Day x Working Days) for Light and Medium load status, and every 200 hours (Operating Time per Day x Working Days) for Heavy and Ultra Heavy load status. (See **Section 2.3**)
- Suspension Pins - Lubricate at least twice per year for normal usage; more frequently for heavier usage or severe conditions.

6.2 Lubrication – Gearbox

6.2.1 **⚠ CAUTION** When replacing a lubricant due to servicing, etc., use only the genuine lubricant or the acceptable equivalent (listed in the instructions below). **Do NOT** use any oil, mixed grease, or quantity other than that listed below. New hoists are prefilled with the correct type and amount of grease.

6.2.2 Replacing Grease – Change gear grease at least once every 5 years. The grease should be changed more frequently depending on the hoist's usage and operating environment. Refer to ISO Classification for the lifetime. Follow the procedure below for replacing the grease for your hoist:

- 1) Remove the 4 socket bolts (spring washers) securing the gear case. (See **Figure 6-2**)

⚠ CAUTION Be careful that the spring washers do not fall inside the body.

- 2) Lightly tap on the gear case with the plastic hammer while removing it and packing G from the body. Packing G is attached to the gear case and removed together.

⚠ CAUTION **Do NOT** pull on the lead wire of the limit switch.

- 3) Remove the gear 2 assembly from the body. (See **Figure 6-2**)
- 4) Remove the snap ring from the load gear and the load gear. (See **Figure 6-2**)
- 5) Scrape off any grease adhering to the gear 2 assembly, the load gear and the guide pin retainer using the spatula. (See **Figure 6-2**) No other cleaning recommended before reassembly such as clean removed gears in solvent and wipe dry with a clean cloth. Wipe gearcase clean with rags, do not use solvent inside gearcase.

NOTICE

Dispose of the used grease in accordance with local regulations.

- 6) Install the load gear to the body.
 - 7) Apply grease to the perimeter of the load gear. Use 30g of ENEOS Epnoc AP (N) 0 grease.
(See **Figure 6-3**)
 - 8) Install the gear 2 assembly to the body.
 - 9) Apply grease to the perimeter of the pinion. Use 20g of ENEOS Epnoc AP (N) 0 grease.
(See **Figure 6-3**)
 - 10) If packing G is damaged, replace.
 - 11) Set packing G and the gear case on top of the body. Pass the lead wires through the packing G hole. Tap the gear case with the plastic hammer to install the gear case to the body with no gaps. (See **Figure 6-4**)
 - 12) Secure the gear case using the socket bolts and toothed lock washers. Pass the lead wires through the gear case hole. Make sure the lead wires are not pinched by the gear case. Make sure the oil seal is not damaged by the pinion. (See **Figure 6-4**)
- **⚠ WARNING** Using an incorrect type/grade of gearbox grease or the wrong quantity of grease may affect the ability of the hoist to hold the load. Refer to the following for correct types/grades of gearbox grease:
 - Epnoc Grease AP (N) 0 (ENEOS Corporation)
 - Acceptable equivalent: Consistency No. 0 (Industrial general lithium grease)

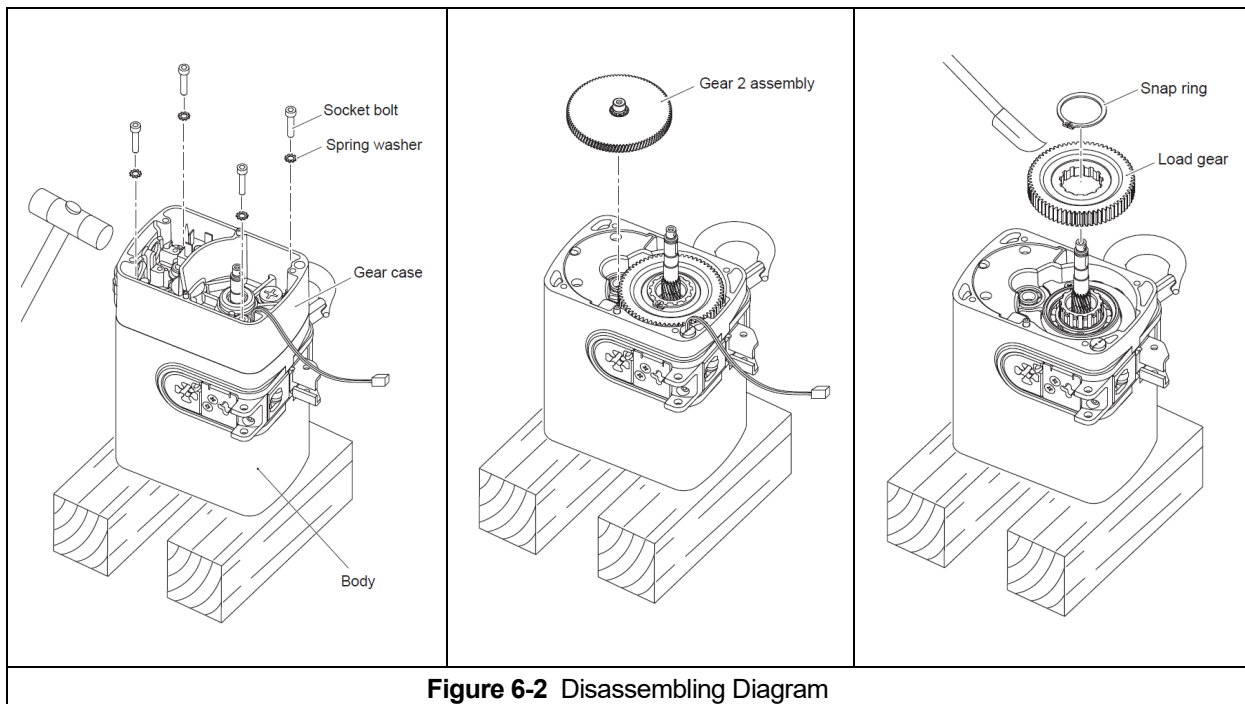

Figure 6-2 Disassembling Diagram

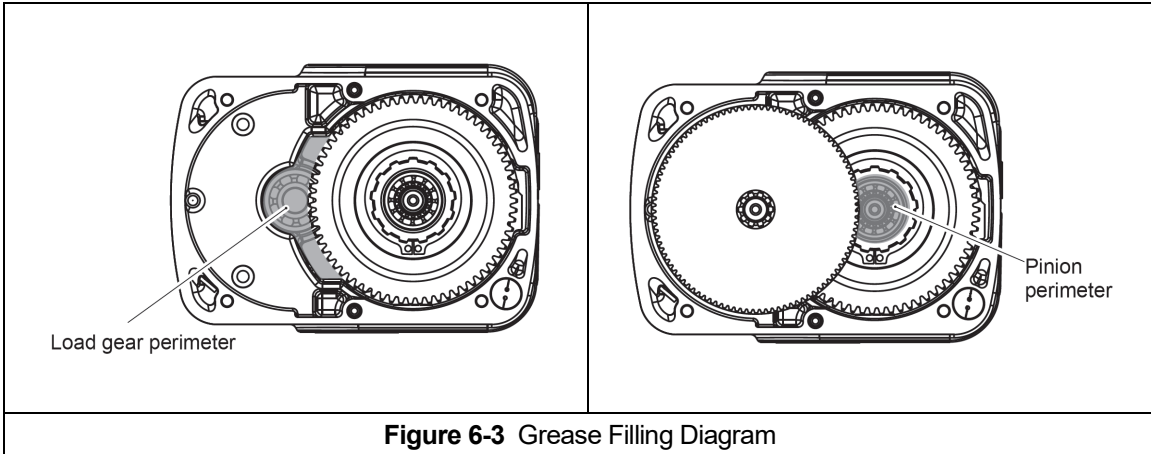

Figure 6-3 Grease Filling Diagram

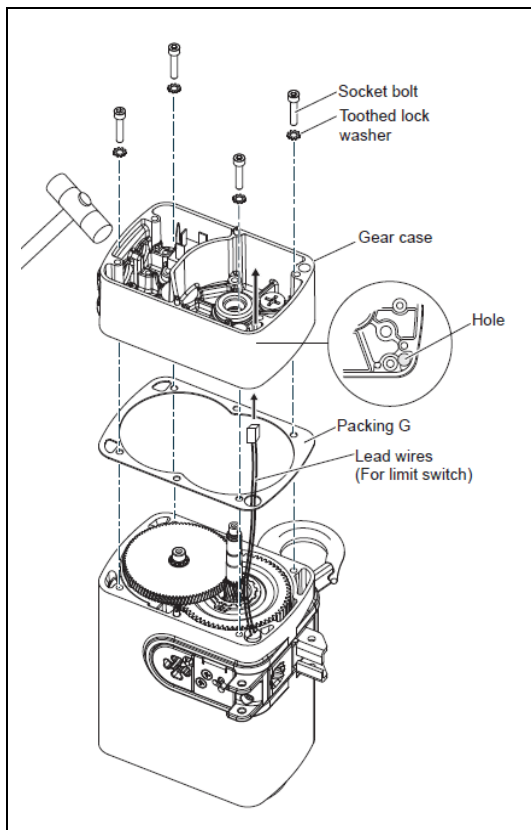

Figure 6-4 Assembling Diagram

*Tightening torque for the Socket Bolts: 8.4 N-m (6.2 lb-ft)

6.3 Motor Brake

- 6.3.1 The motor brake on the (S)EM hoist is not adjustable.
- 6.3.2 Refer to **Section 5.8** and **Table 5-11** for Brake Gap/Wear criteria.
- 6.3.3 When the number of starts reaches one million times, replace the brake.

6.4 Single-phase Starting Capacitor Replacement

6.4.1 When the number of starts reaches one million times, replace the single-phase starting capacitor.

6.5 Load Chain

6.5.1 Lubrication and Cleaning – refer to **Section 6.1**.

6.5.2 Load Chain Replacement:

- 1) **⚠ CAUTION** The hoist must be properly powered and operational in order to perform the following procedures.
- 2) **⚠ WARNING** Be certain that the replacement chain is obtained from Harrington Hoists, Inc./KITO and is the exact size, grade and construction as the original chain. The new load chain must have an odd number of links so that both its end links have the same orientation. If the load chain is being replaced due to damage or wear out, destroy the old chain to prevent its reuse.
- 3) **⚠ CAUTION** When replacing load chain, check for wear on mating parts, i.e. Load Sheave, Chain Guides and Idle Sheaves, and replace parts if necessary.
- 4) Remove all chain components including the Bottom Hook Set Assembly, Stoppers, Cushion Rubbers, Chain Pin and Chain Clip from the chain for reuse on new chain. Inspect and replace any damaged or worn parts.
- 5) Using a C-link, attach the new chain to the end link of the old chain on the no-load side. The end link of the new load chain should be connected so that the welded portions of the load chain's standing links are oriented to the outside as they pass over the sheave. Refer to **Figure 6-5**.
- 6) Operate the hoist down to move the chain through the hoist body. Stop when a sufficient amount of new chain is accumulated on the load side.
- 7) Single fall hoists - Attach the chain components (step 4 above) to the chain. Refer to **Section 3.2** for the proper locations.
- 8) Double falls (050C) - Feed the end link on the load side of the new chain through the required chain components (step 4 above) and the bottom hook's Idle Sheave. Attach the remaining chain components to the chain referring to **Section 3.2** for the proper locations. Connect the end link to the Chain Guide A with the Chain Pin, Pin Stopper, and socket bolts. Ensure that chain remains free of twists. Refer to **Section 3.2.4**.
- 9) **⚠ WARNING** Make sure Stoppers and Cushion Rubbers are properly installed. Refer to **Section 3.2.1**.
- 10) After installation has been completed, perform steps outlined in **Section 3.6**, "Initial Inspection and Trial Operation".

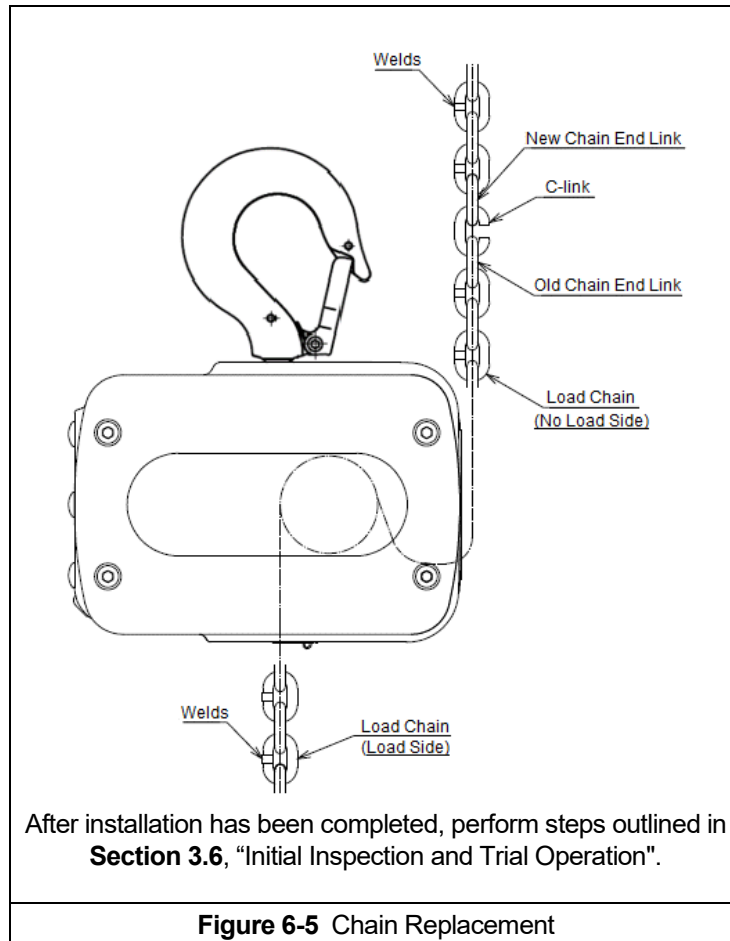

6.6 Storage

6.6.1 **IMPROPER** chain hoist use could result in death or serious injury. To avoid these hazards:

- ALWAYS store the hoist in a no load condition.
- ALWAYS wipe off all dirt and water.
- ALWAYS oil the chain, hook pins and hook latches.
- ALWAYS hang in a dry place.
- ALWAYS check the hoist for abnormalities (according to the regular inspection procedures) when using the hoist after a period of non-use.

6.6.2 **⚠ WARNING** Do **NOT** drop or throw the hoist.

6.7 Outdoor Installation

6.7.1 When installing the electric chain hoist outdoors or to the place where the hoist is exposed to direct rain, wind and snow, shade the hoist with roof to store it in protection against rain, wind and snow.

6.7.2 The hoist/trolley should be covered when not in use.

6.7.3 The hoist/trolley **MUST BE** inspected and maintained according to the 'Severe Service' Inspection Classification. Refer to **Section 5.0**.

6.7.4 When reinstalling the control cover, the gasket **MUST BE** in good condition and installed properly to preserve the IP65 rating of the hoist.

6.7.5 When using a plastic chain container, drill a 1/8" hole in the plastic to allow for drainage. Canvas chain containers are not recommended for outdoor use.

6.7.6 Possibility of corrosion on components of the hoist/trolley increases for installations where salt air and high humidity are present. For installations where temperature variations introduce condensation/corrosion into the hoist, more frequent lubrication may be required.

6.7.7 NEMA 4 Pendants are recommended for outdoor use.

6.7.8 Refer to **Section 2.1.3** for allowable environmental conditions.

6.8 Operational Environment

6.8.1 Non-conforming environment

A non-conforming environment is defined as one with any or all of the following.

- Flammable or Explosive gases or vapor.
- Organic solvents or volatile powder.
- Excessive amounts of powder and dust of general substances.
- Excessive amounts of acids or salts.
- Submerged in water.

7.0 Troubleshooting

⚠ WARNING

HAZARDOUS VOLTAGES ARE PRESENT IN THE HOIST AND IN CONNECTIONS BETWEEN COMPONENTS.

Before performing ANY maintenance on the equipment, de-energize the supply of electricity to the equipment, and lock and tag the supply device in the de-energized position. Refer to ANSI Z244.1, "Personnel Protection – Lockout/Tagout of Energy Sources."

To avoid a shock hazard, **DO NOT** perform **ANY** mechanical or electrical maintenance on the hoist within 5 minutes of de-energizing (disconnecting) the hoist. This time allows the internal capacitor to safely discharge.

Personnel assigned to inspect, maintain, and troubleshoot this equipment shall meet the definition of **Designated Person**.

7.1 Operation and Error Codes

The operation and error code can be checked with blinking of the LED installed on the SSR. The SSR always recognizes an electric status by itself and indicates it with a LED color and a blinking light pattern. The LED is located on the upper left of the SSR on the back of the controller cover (see **Figure 7-1**).

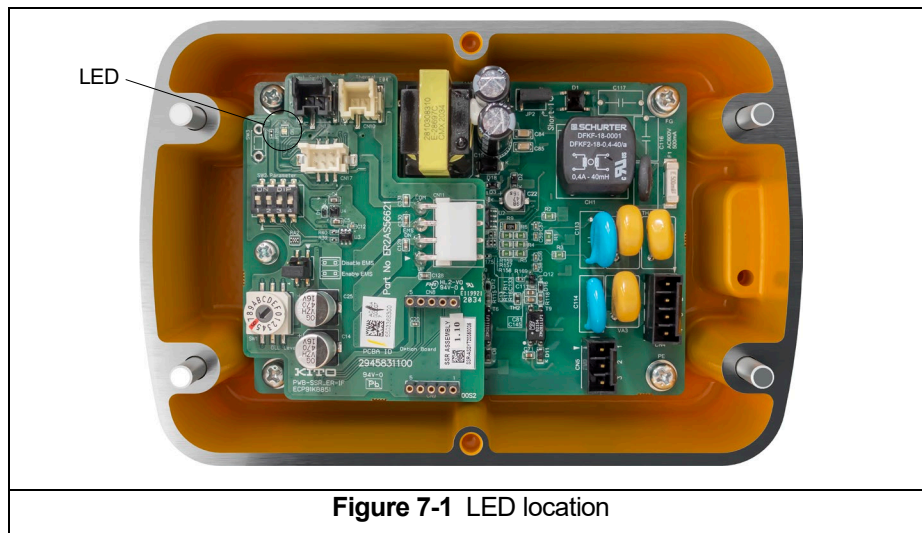

Figure 7-1 LED location

7.1.1 Operational Codes

- Indication during normal operation - During normal operation, the LED is turned on or blinking in green. (See **Figure 7-2**)



Figure 7-2 Green Light

It remains turned on all the time during standby and assumes the following indication patterns during an emergency stop or operation (see **Figure 7-3**).

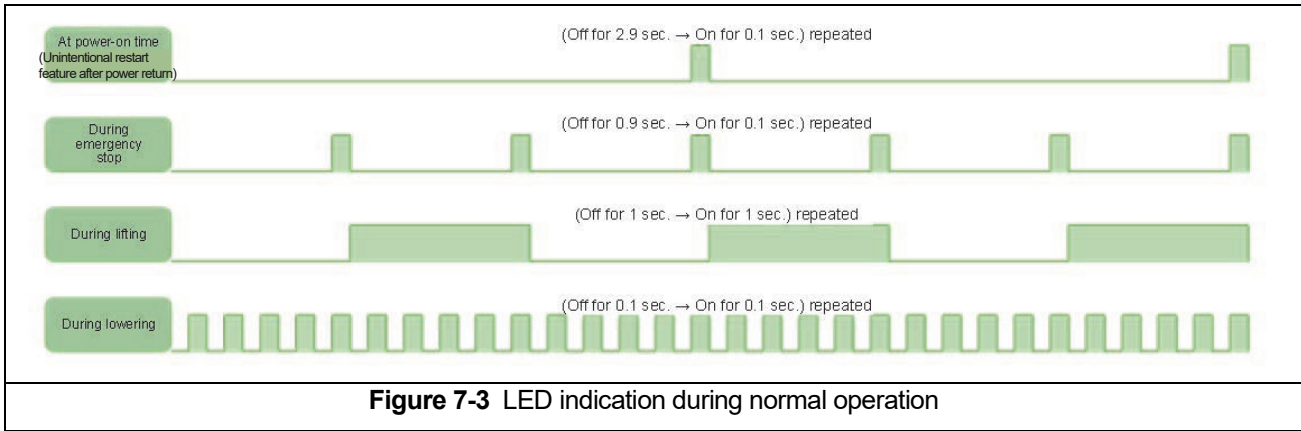

7.1.2 Error Codes

- Indication during an error - During an error, the LED blinks in orange or red. (See **Figure 7-4**)

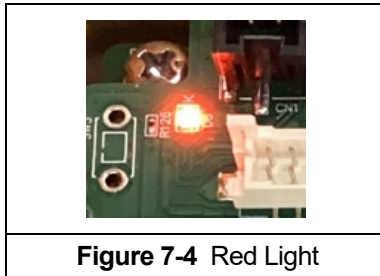

One complete error indication cycle is 14 seconds. A series of orange blinks displays in the first 4 seconds. The number of orange blinks signifies the “tens” place value of its error code. The red blinks display in the remaining 10 seconds. The number of red blinks signifies the “ones” place value of its error code. Reference the example in **Figure 7-5**.

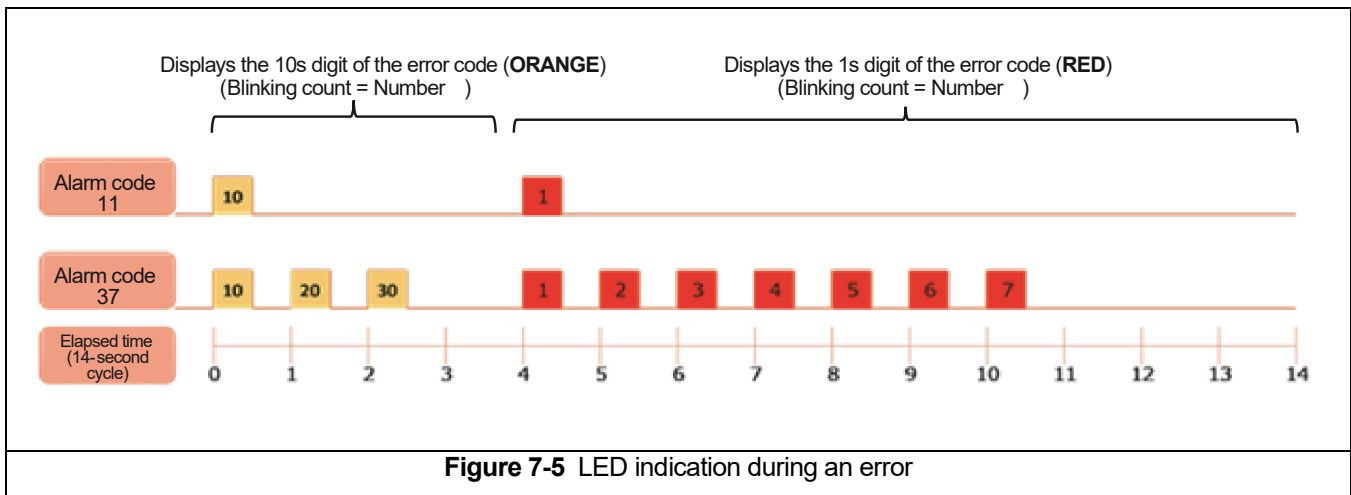

7.1.3 List of Error Codes - **Table 7-1** lists the typical error codes. If there is an error code found that is

unspecified in this table, contact Harrington/KITO product support. Refer to **Table 7-2** to troubleshoot these error codes.

Table 7-1 Error Codes				
Error		Designation	Cause	Remedy
Code	LED blinking count			
12	Orange: 1 time Red: 2 times	Overload protection	The electronic overload limiter was activated.	Reduce load to within rated capacity of hoist. (See Section 7.1.4)
			The lower-limit limiter was activated. (Chain stopper engaged hoist body.)	Lift Bottom Hook. (See Section 7.1.4)
13	Orange: 1 time Red: 3 times	Limit Switch activation	The upper-limit limit switch was activated.	Lower Bottom Hook.
15	Orange: 1 time Red: 5 times	Circuit Board temperature error	The power module of the SSR exceeded the set temperature.	Cool hoist body. Check ambient temperature and frequency of hoist operation.
16	Orange: 1 time Red: 6 times	Motor temperature error	The thermal protector of the motor was activated.	Cool hoist body. Check ambient temperature and frequency of hoist operation.
21-22	Orange: 2 times Red: 1 time or 2 times	Power error	The supply voltage is not within the limit.	Check voltage, frequency, and Power Supply Cable damages.
23	Orange: 2 times Red: 3 times	Power open phase	The input power has an open phase. (3-phase only)	Check phase loss.
24	Orange: 2 times Red: 3 times	Overcurrent	An excessive output current was detected.	Check voltage. Check if drivetrain is locked.
25	Orange: 2 times Red: 5 times	Output open phase	There is an open phase on the output side of the SSR.	Check electrical continuity of Motor, and between SSR Bord and Motor. Replace Motor
31	Orange: 3 times Red: 1 time	Motor control parameter error	The power is used beyond the limits of ratings. The SSR's DIP switch, rotary switch or jumper wire is wrong. The SSR internal data are corrupted.	Check power supply voltage, phase and DIP switch setting are correct. Replace Controller Cover Assembly.

7.1.4 Resetting the Hoist After an Error - If the Electronic Overload Limiter or Electronic Lower-limit Limiter is

activated, there are two resetting methods:

- 1) Turn on and off the Emergency Stop Button to reset the error.
- 2) Hold down the Upper/Lower Button for 2 seconds or more.
 - When the Electronic Overload Limiter is activated, hold down the Lower Button for 2 seconds or more.
 - When the Electronic Lower-limit Limiter is activated, hold down the Lift Button for 2 seconds or more.

If the error cannot be reset by the above method, shut off the power and correct the cause of the error. Then, turn on the power again. If necessary turn on and off the Emergency Stop Button to reset the error.

7.2 Troubleshooting Guide

Table 7-2 Troubleshooting Guide		
Symptom	Cause	Remedy
Hoist moving in wrong direction	Improper electrical connections	Refer to wiring diagram and check all connections.
Press UP button and hoist lowers	Low voltage in hoist's power supply	Determine cause of low voltage and bring to within plus or minus 10% of the voltage specified on the motor nameplate. Supply proper voltage.
Hoist will not operate	Breaker was tripped due to short circuit.	Replace or repair the short circuited part.
	Breaker was tripped due to insufficient breaker capacity.	Check the breaker capacity. Replace it if the capacity is insufficient.
	Breaker was tripped due to overcurrent.	Check the cause of overcurrent and take the necessary countermeasure. (Refer to each item of Power Cable, Motor, Brake, Internal wiring.)
	Loss of power	Check circuit breakers, switches, fuses, and connections on power lines/cable.
	Wrong voltage or frequency	Check voltage and frequency of power supply against the rating on the nameplate of the motor.
	Hoist overloaded	Reduce load to within rated capacity of hoist.
	Motor overheated and thermal overload protector has tripped	See Trouble Shooting Problem "Motor or brake overheating".
	Improper, loose, or broken wire in hoist electrical system	Shut off power supply, check wiring connections on hoist control panel and inside push-button pendant.
	Brake does not release	Check motor brake coil for continuity. Replace brake if needed.

Table 7-2 Troubleshooting Guide

Symptom	Cause	Remedy
Hoist will not operate (continued)	Faulty SSR Board	Replace Controller Cover Assembly.
	Emergency Stop Depressed on Push Button Pendant Control	Turn the Emergency Stop Button clockwise to unlock the controls and allow hoist operation.
	Motor burned out	Measure the coil resistance of each phase. Replace motor frame/stator, shaft/rotor, and any other damaged parts.
	Short-circuited or open capacitor	When the capacity is measured, the measured value is 0 or close to infinite. Replace the capacitor.
	Drive component broken	Replace the drive components.
	Bearing stuck	Replace the bearing.
	SSR error	Check error codes (Reference Section 7.1), follow countermeasures, and reset accordingly.
	Broken SSR Board	Check for cracks or damaged components. Replace Controller Cover Assembly.
Hoist lifts but will not lower	Down circuit open	Check circuit for loose connections. Check down side of limit switch for malfunction.
	Broken conductor in pendant cord	Check the continuity for each conductor in the cable. If one is broken, replace entire cable.
	Faulty switch in pendant	Check electrical continuity. Check electrical connections. Replace or repair the parts as needed.
	Broken SSR Board	Check for cracks or damaged components. Replace Controller Cover Assembly.
Hoist lowers but will not lift	Hoist overloaded	Reduce load to within rated capacity of hoist.
	Low voltage in hoist's power supply	Determine cause of low voltage and bring to within plus or minus 10% of the voltage specified on the motor nameplate. Supply proper voltage.
	Up circuit open	Check circuit for loose connections. Check up side of limit switch for malfunction.
	Broken conductor in pendant cord	Check the continuity of each conductor in the cable. If one is broken, replace entire cable.
	SRR Error	Check error codes (Reference Section 7.1), follow countermeasures, and reset accordingly.
	Faulty switch in pendant	Check electrical continuity. Check electrical connections. Replace or repair as needed.
	Faulty friction clutch	Replace.
	Broken SSR Board	Check for cracks or damaged components. Replace Controller Cover Assembly.

Table 7-2 Troubleshooting Guide

Symptom	Cause	Remedy
Hoist will not lift rated load or does not have the proper lifting speed	Hoist overloaded	Reduce load to within rated capacity.
	Low voltage in hoist's power supply	Determine cause of low voltage and bring to within plus or minus 10% of voltage specified on the motor nameplate. Supply proper voltage. Check the cable size for adequacy. Replace with the proper cable if the cable capacity is insufficient.
	Brake drags/chatters	Check SSR for error codes.
	Faulty Friction clutch	Replace Rotor Assembly.
	Short-circuited or open capacitor	When the capacity is measured, the measured value is 0 or close to infinite. Replace the capacitor.
Load drifts excessively when hoist is stopped	Wear of Brake Lining	Measure the brake gap. If the gap exceeds the service limit, replace the Electromagnetic Brake unit as a whole. (Refer to Table 5-11)
Hoist does not stop when pendant switch released	Broken pendant switch	Replace pendant switch.
Hoist does not stop at upper limit switch	Broken limit switch	Replace limit switch.
E-stop does not function	E-stop circuit open	Check for broken connection in pendant
	Faulty switch in pendant	Check electrical continuity. Check electrical connections. Replace or repair as needed.
	Jumper Pin is not set properly	Ensure that the Jumper Pin is set properly on the SSR board (see Figure 7-6)
Electromagnetic Brake does not operate	Brake coil burning	Measure the coil resistance of the Brake coil. Replace the Electromagnetic Brake when the resistance is infinity.
	Wear of Brake Lining	Measure the brake gap. If the gap exceeds the service limit, replace the Electromagnetic Brake unit as a whole. (Refer to Table 5-11)
	Breakage of Electromagnetic Brake lead wire	Check the continuity of the lead wire. Replace the wire without continuity.
	Insufficient connection of brake lead wire at insertion terminal	Connect the insertion terminal securely. Replace the loose insertion terminal if any.
	Rusting	When the Brake is rusted shut, replace the Brake unit as a whole.
	Breakage of rectifier	Use a tester to measure the forward voltage value of the rectifier. (See Figure 7-7) Meter should be set to diode test position  Disconnect wires from rectifier before testing. Refer to Table 7-3 for the expected result. In other cases, replace the rectifier.

Table 7-2 Troubleshooting Guide

Symptom	Cause	Remedy
Motor or brake overheating	Excessive load	Reduce load to within rated capacity of hoist.
	Excessive duty cycle	Reduce frequency of lifts.
	Wrong voltage or frequency	Check voltage and frequency of power supply against the rating on the nameplate on the motor.
	Brake drags/chatters	Check SSR for error codes.
	Extreme external heating	Above an ambient temperature of 140°F, the frequency of hoist operation must be reduced to avoid overheating of the motor. Special provisions should be made to ventilate the hoist or otherwise shield it from the heat.
Hoist operates intermittently	Collectors making poor contact	Check movement of spring loaded arm, weak spring, connections, and shoe. Replace as needed.
	Loose connection in circuit	Check all wires and terminals for bad connections. Replace as needed.
	Broken conductor in Pendant Cord	Check for intermittent continuity in each conductor the Pendant Cord. Replace entire Pendant Cord if continuity is not constant.
	Broken SSR Board	Check for cracks or damaged components. Replace Controller Cover Assembly.
Louder operating sounds or abnormal sounds	Worn Load Chain	Measure wire diameter, pitch dimensions. Replace if the value exceeds the limit. Check for rust, nicks, gouges, dents weld splatter, and deformations and replace if found.
	Worn Load Sheave	Check for wear and deformations. Measure wall thickness and replace if the value exceeds the limit.
	Broken or worn gearing	Replace the gear.
	Faulty bearing	Replace the bearing.
	Worn Brake Lining	Measure the brake gap. If the gap exceeds the service limit, replace the Electromagnetic Brake unit as a whole. (Refer to Table 5-11)
	Worn Brake hub	Replace the Electromagnetic Brake unit as a whole if it has apparent deformation or wear.
	Loose mounting bolts on Brake	Improper torque at mounting. Tighten the bolts at proper torque.
	Unlubricated and or dirty chain	Clean and lubricate load chain.

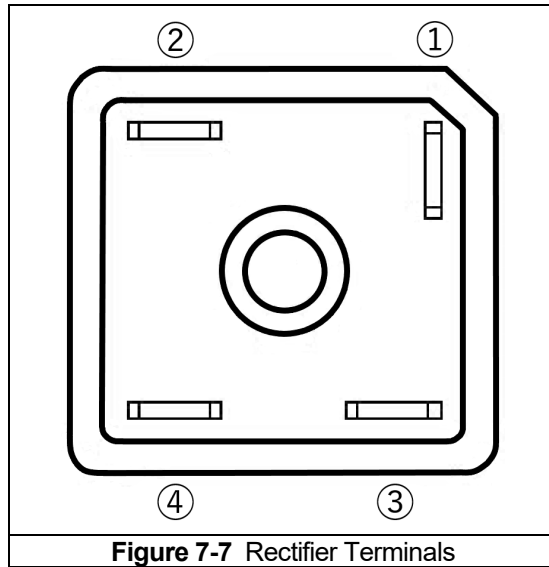
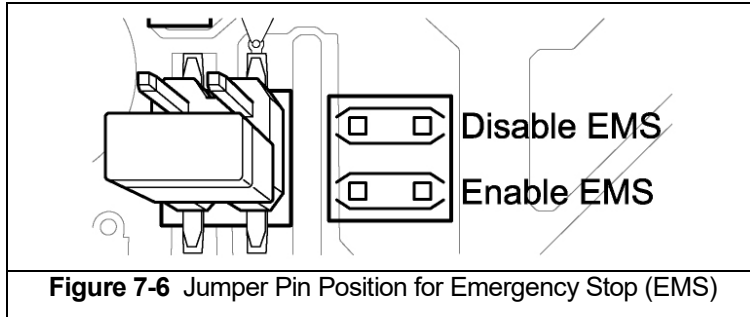

Table 7-3 EM Brake Rectifier Test		
Meter Leads		Expected Result
Red	Black	
Terminal 1(+)	Terminals 2(AC),3(AC),4(-)	OL
Terminal 2(AC)	Terminal 3(AC)	OL
Terminal 3(AC)	Terminal 2(AC)	OL
Terminal 4(-)	Terminal 1(+)	0.9V to 1V
Terminal 4 (-)	Terminals 2(AC) or 3(AC)	0.5 to 0.6V
Terminals 2(AC) or 3(AC)	Terminal 1(+)	0.5 to 0.6V

8.0 Warranty

All products sold by Harrington Hoists, Inc. are warranted to be free from defects in material and workmanship from date of shipment by Harrington for the following periods:

- 1 year – Electric and Air Powered Hoists (excluding (N)ER2 Hoists and EQ/SEQ Hoists, (T)EM/(T)SEM Hoists, Powered Trolleys, Powered Tiger Track Jibs and Gantries, Crane Components, Below the Hook Devices, Spare / Replacement Parts**
- 2 years – Manual Hoists & Trolleys, Beam Clamps**
- 3 years – (N)ER2 Hoists, EQ/SEQ Hoists, (T)EM/(T)SEM Hoists, and RY Hoists**
- 5 years – Manual Tiger Track Jibs and Gantries, TNER, EQ/SEQ, (T)EM/(T)SEM, and RY Hoist Motor Brakes**
- 10 years – (N)ER2 “The Guardian” Smart Brake**

The product must be used in accordance with manufacturer’s recommendations and must not have been subject to abuse, lack of maintenance, misuse, negligence, or unauthorized repairs or alterations.

Should any defect in material or workmanship occur during the above time period in any product, as determined by Harrington Hoist’s inspection of the product, Harrington Hoists, Inc. agrees, at its discretion, either to replace (not including installation) or repair the part or product free of charge and deliver said item F.O.B. Harrington Hoists, Inc. place of business to customer.

Customer must obtain a Return Goods Authorization as directed by Harrington or Harrington’s published repair center prior to shipping product for warranty evaluation. An explanation of the complaint must accompany the product. Product must be returned freight prepaid. Upon repair, the product will be covered for the remainder of the original warranty period. Replacement parts installed after the original warranty period will only be eligible for replacement (not including installation) for a period of one year from the installation date. If it is determined there is no defect, or that the defect resulted from causes not within the scope of Harrington’s warranty, the customer will be responsible for the costs of returning the product.

Harrington Hoists, Inc. disclaims any and all other warranties of any kind expressed or implied as to the product’s merchantability or fitness for a particular application. Harrington will not be liable for death, injuries to persons or property or for incidental, contingent, special or consequential damages, loss or expense arising in connection with the use or inability whatever, regardless of whether damage, loss or expense results from any act or failure to act by Harrington, whether negligent or willful, or from any other reason.

This Page Intentionally Left Blank

9.0 Parts List

When ordering Parts, please provide the Hoist code number, lot number and serial number located on the Hoist nameplate (see fig. below).

Reminder: Per **Sections 1.1** and **3.6.6** to aid in ordering Parts and Product Support, record the Hoist code number, lot number and serial number in the space provided on the cover of this manual.

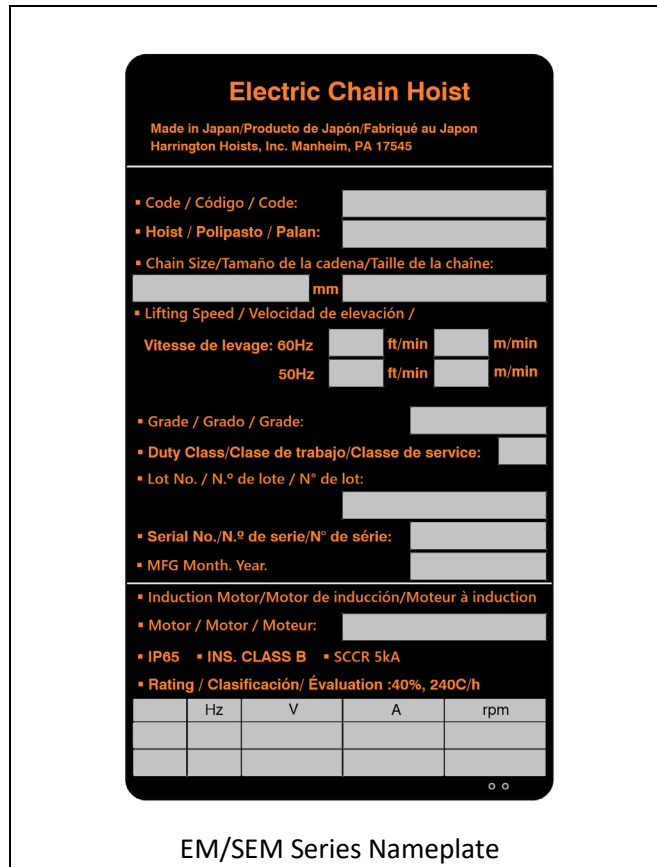

EM/SEM Series Nameplate

The parts list is arranged into the following sections:

Section	Page
9.1 Housing and Gearing Parts.....	62
9.2 Hook and Chain Parts.....	64
9.3 Electric Parts.....	66
9.4 Power Supply and Pendant Parts.....	68
9.5 Nameplates and Warning Labels.....	69

In the column "Parts Per Hoist" a designator is used for parts that apply only to a particular model or option. Refer to **Section 2.0** for hoist model numbers and additional descriptions. The designators are:

1V = 115 Volt Class Models
 2V = 230 Volt Class Models
 4V = 460 Volt Class Models

Blank = Common Parts

9.1 Housing and Gearing Parts

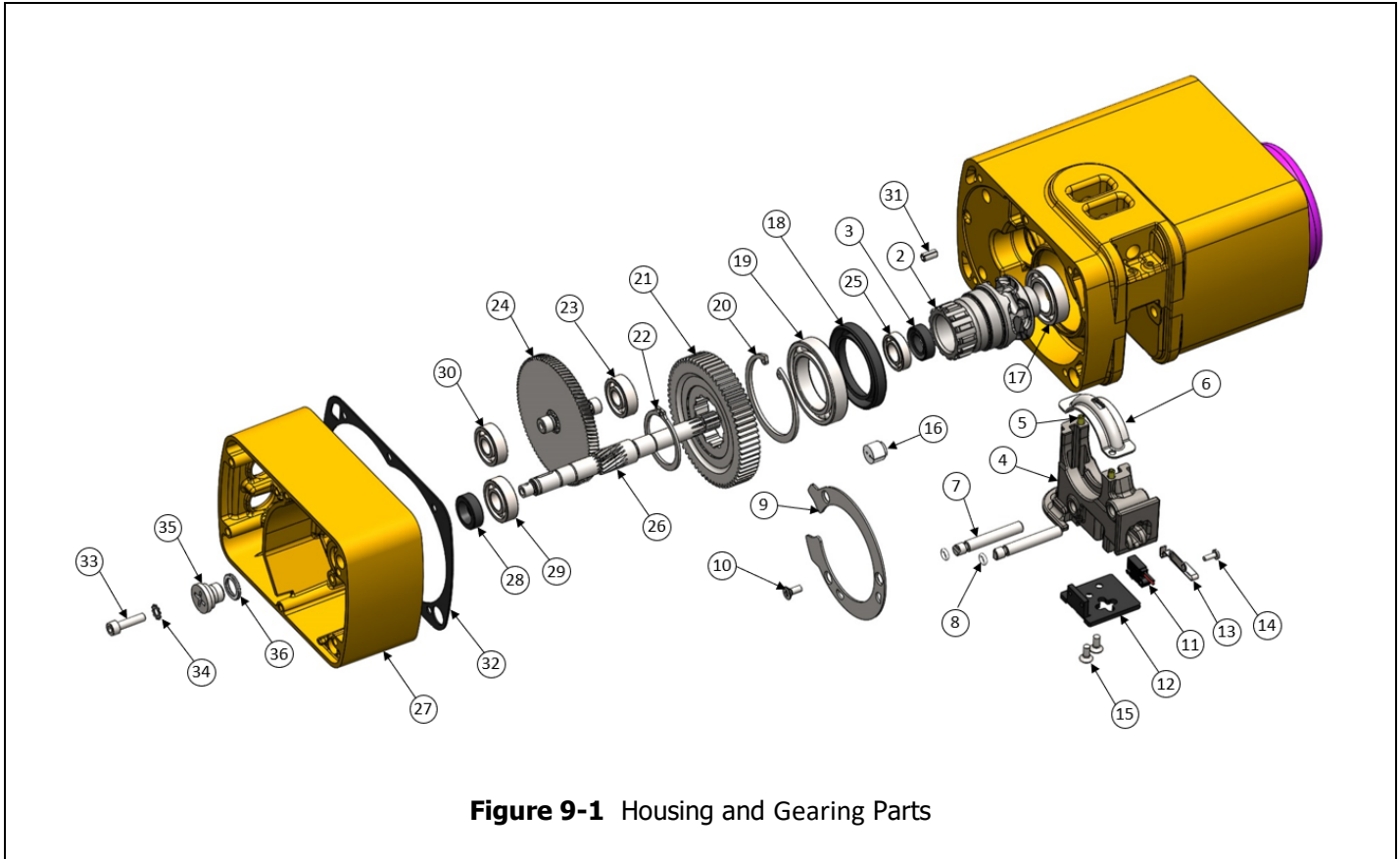

Figure 9-1 Housing and Gearing Parts

Figure No.	Part Name	Parts Per Hoist	EM001S	EM003L	EM005C	SEM003L	SEM005C
2	Load Sheave Assembly *	1			ER2AS5241		
3	Oil Seal	1			ER2AS9233		
4	Chain Guide A **	1			ER2AS9331		
5	Spring Pin	2			9148149		
6	Chain Guide B	1			ER2AS9332		
7	Chain Guide Pin ***	2			ER2AS9387		
8	O Ring	2			9013302		
9	Guide Pin Retainer	1			ER2AS9389		
10	Flat Head Machine Screw	3			9096528		
11	Limit Switch Assembly	1			ER2AS5380		
12	Limit Cover	1			ER2AS9381		
13	Limit Spring	1			ER2AS9382		
14	Pan Head Machine Screw	1			9798512		
15	Flat Head Machine Screw	2			9096529		
16	Packing LS	1			ER2AS9385		
17	Ball Bearing	1			9001239		
18	Oil Seal	1			ER2AS9244		
19	Ball Bearing	1			9001236		
20	Snap Ring	1			9047255		

* #18 Oil Seal must be replaced when removing Load Sheave form Body

** #5 Spring Pin must be supplied together when replacing Chain Guide A

*** #8 O Ring must be supplied together when replacing Chain Guide Pin

9.1 Housing and Gearing Parts

Figure No.	Part Name	Parts Per Hoist	EM001S	EM003L	EM005C	SEM003L	SEM005C
21	Load gear	1	ER2AS9240	ER2AL9240		EP2AL9240	
22	Snap ring	1	9047135				
23	Ball bearing	1	9000500				
24	Gear2 assembly	1	ER2AS5223	ER2AL5223		EP2AL5223	
25	Ball bearing	1	9001237				
26	Pinion	1	ER2AS9220			EP2AL9220	
27	Gear case *	1	ER2AS9103				
28	Oil seal	1	ER2AS9233				
29	Ball bearing	1	9000501				
30	Ball bearing	1	9000500				
31	Spring Pin	2	9148180				
32	Packing G	1	ER2AS9116				
33	Socket Bolt	4	9091230				
34	Toothed Lock Washer	4	9679708				
35	Oil Plug	1	E3S111003				
36	Plug Packing	1	E3S112003				

* #28 Oil Seal must be supplied together when replacing Gear Case

9.2 Hook and Chain Parts

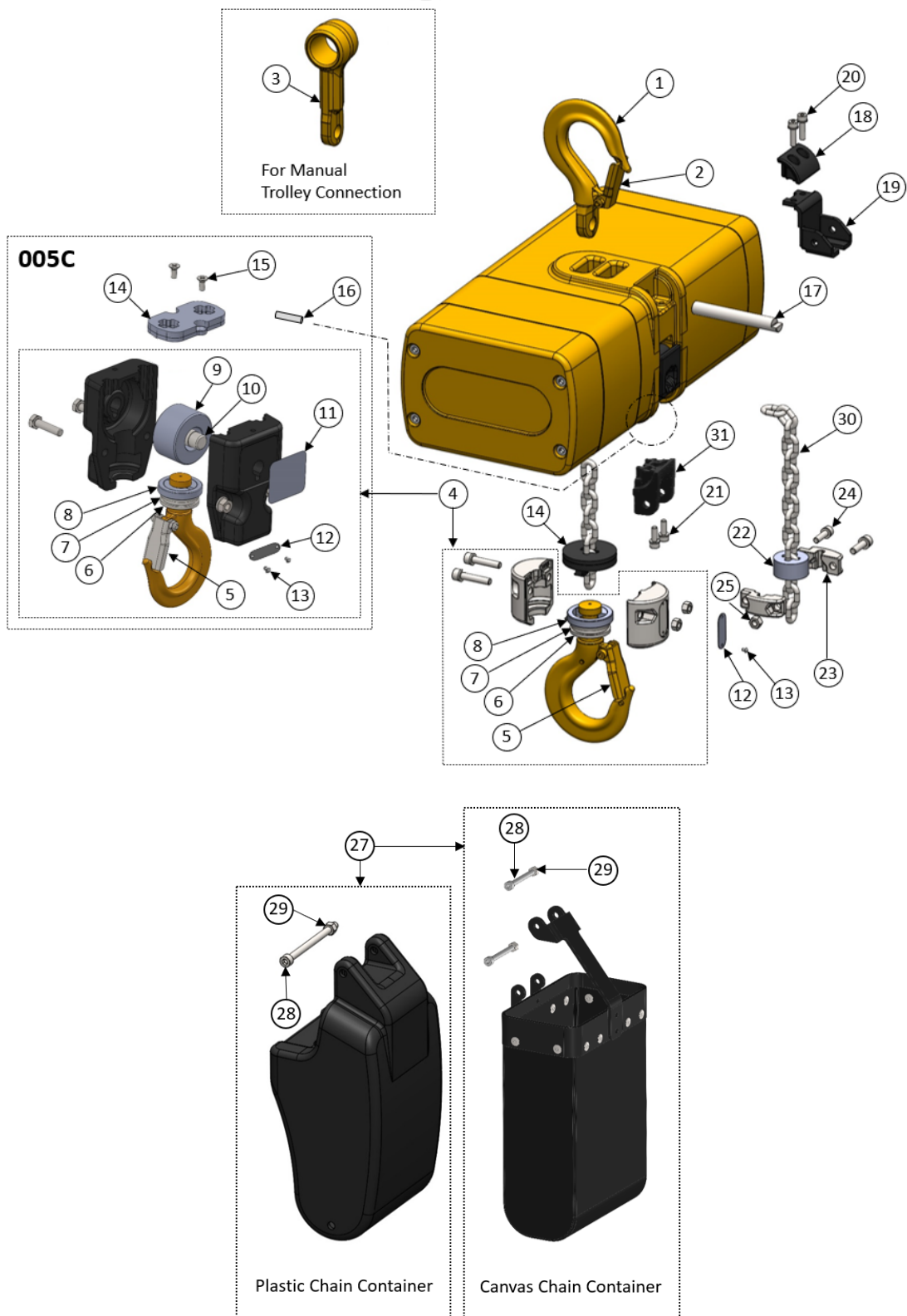

Figure 9-2 Hook and Chain Parts

9.2 Hook and Chain Parts

Figure No.	Part Name	Parts Per Hoist	EM001S	EM003L	EM005C	SEM003L	SEM005C	
1	Top Hook Assembly	1	ER2AS1001					
	Hook Latch	1	L1XA0051071					
3	Suspender P	1	ER2AS9027					
4	Bottom Hook Complete Set	1	ER2AS1011		EMB1AU1011	ER2AS1011	EMB1AU1011	
	Hook Latch	1	L1XA0051071					
	Thrust Bearing	1	AH130121103					
	Thrust Collar A	1	ES026003					
	Thrust Stopper A	2	ES027003					
	Idle Sheave Assembly	1			E3DBX48S6487		E3DBX48S6487	
	Bottom Shaft Assembly	1			E3DBX48S6489		E3DBX48S6489	
	Name Plate C	1			E3DBX48S9597		E3DBX48S9597	
12	Name Plate CH	2	80758	80759	80770	80760	80771	
13	Drive Screw Rivet	4	9005706					
14	Cushion Rubber	1	ER2AS9053		SA2AU9053	ER2AS9053	SA2AU9053	
15	Flat Head Machine Screw	2			9096529		9096529	
16	Chain Pin	1			SA2AU9035		SA2AU9035	
17	Top Pin	1	ER2AS9121					
18	Pin Stopper	1	ER2AS9367					
19	Bucket Bracket	1	ER2AS9369					
20	Socket Bolt w/ Spring Washer	2	J1BG2-0401616					
21	Socket Bolt w/ Spring Washer	2	J1BG2-0401212					
22	Cushion Rubber	1	ER2BS9053					
23	Stopper	2	ER2AS9041					
24	Socket Bolt w/ Spring Washer	2	J1BG1-0501818					
25	Nut	2	9093417					
27	Chain Container P Set (Max Lift: 13 ft._4m)	1	ER2AS2401			ER2AS2401		
	Chain Container (A1) Set (Max Lift for Single: 30 ft._9m, Max Lift for Double: 15 ft._4.5m)	1	EMB1AS1403					
	Chain Container (A2) Set (Max Lift for Single: 60 ft._18m, Max Lift for Double: 30 ft._9m)	1	EMB1AS1405					
	Chain Container (A3) Set (Max Lift for Single: 120 ft._36m, Max Lift for Double: 60 ft._18m)	1	EMB1AS1406					
	28	Socket Bolt (For Chain Container P Assembly)	1	9091536			9091536	
		Socket Bolt (For Chain Container A1, A2, A3)	2	9091534				
	29	Nut (For Chain Container P Assembly)	1	E2D853125			E2D853125	
Nut (For Chain Container A1, A2, A3)		2	E2D853125					
30	Load Chain	1	LCED125NP					
31	Bucket Bracket C	1	ER2AS9369					
32	Pin Stopper	1	J1BG2-040161					

9.3 Electric Parts

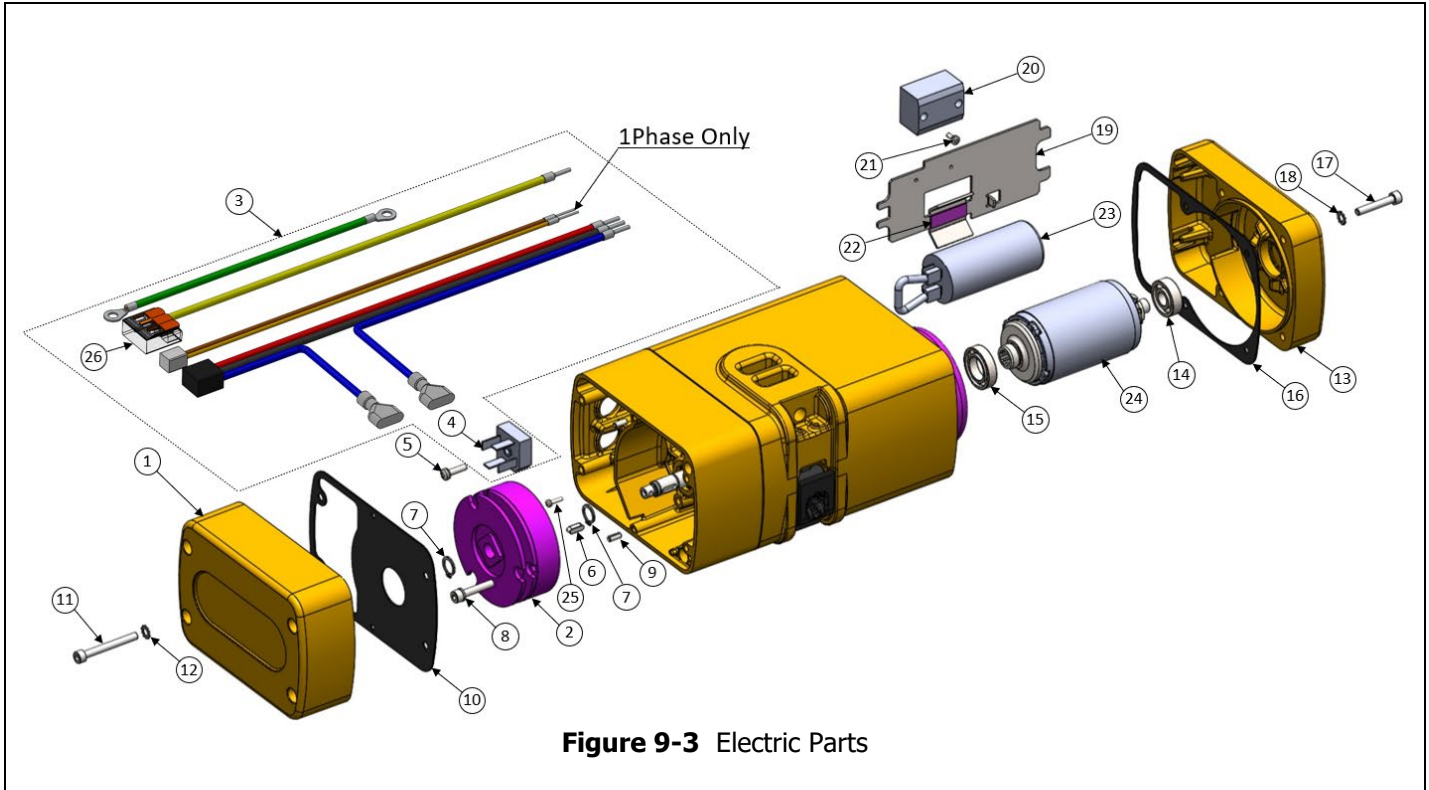

Figure 9-3 Electric Parts

Figure No.	Part Name	Parts Per Hoist	EM001S	EM003L	EM005C	SEM003L	SEM005C
1	Controller Cover Assembly *	1			ER2AS5104		
2	Electromagnetic Brake	2V	1		MBABB0BCA		
		4V	1		MBABB0BYA		
		1V	1			MBABB0BGA	
		2V	1			MBABB0BCA	
3	Lead Wire Assembly	1			ER2AS5698	EP2AL5698	
4	Rectifier	1			ECP93DIAA		
5	Pan Head Machine Screw w/ Spring Washer	1			MS556010		
6	Key B	1			ER2AS9360		
7	Snap Ring	2			L4188015		
8	Socket Bolt w/ Spring Washer	3			J1BG1-0502828		
9	Spring Pin	2			9148149		
10	Packing C	1			ER2AS9117		
11	Socket Bolt	4			9091534		
12	Toothed Lock Washer	4			9679708		
13	Motor Cover	1			ER2AS9106		
14	Ball Bearing	1			9000900		
15	Ball Bearing	1			9001238		
16	Packing M	1			ER2AS9118		
17	Socket Bolt	4			9091537		

*Branding label 80743 should also be ordered. Controller dip switches to be set by qualified person per SSR Setting Manual for EM Electric Chain Hoist.

9.3 Electric Parts

Figure No.	Part Name	Parts Per Hoist		EM001S	EM003L	EM005C	SEM003L	SEM005C
18	Toothed Lock Washer	4		9679708				
19	Back Panel	1		ER2AS9391				
20	Terminal Block 6P	1		ECP1306AH				
21	Pan head Machine Screw w/ Spring Washer & Plain Washer	2		J1AX2-3000707				
22	Rubber Sheet	1					EP2AL9394	
23	Capacitor Assembly	1V	1				ECP99CP15	
		2V	1				ECP99CP16	
24	Rotor Assembly	1		ER2AS1502			EP2AL1502	
25	Pan Head Machine Screw w/ Spring Washer & Plain Washer	2		J1AX2-4000808				
26	Splicing Connector	1					9009120	

9.4 Power Supply and Pendant Parts

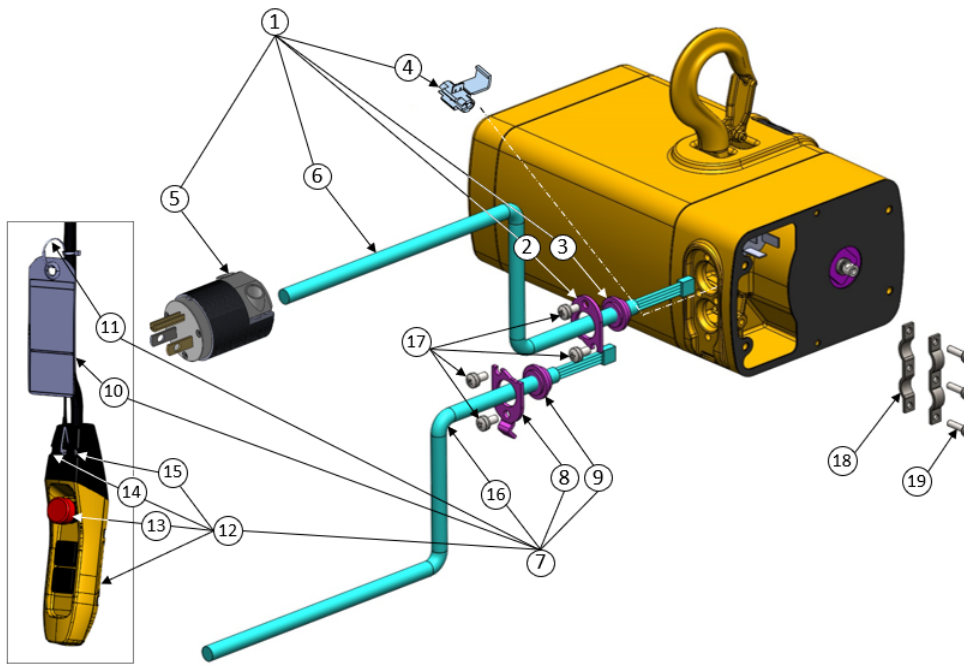

Figure 9-4 Power Supply and Pendant Parts

Figure No.	Part Name	Parts Per Hoist		EM001S	EM003L	EM005C	SEM003L	SEM005C
1	Power Supply Cable Assembly	1		ZPZB11CH1000				
		1V	1				83520	
		2V	1				ZPZH11CH1000	
2	Holder Plate A	1				ER2AS9484		
3	Cable Packing C9	1				E2DDX10A9526		
4	Connector (3M 560)	1					9012359	
5	Plug (5-15P)	1V	1				9006301	
6	Power Supply Cable	ft			16/4		16/3	
7	Pendant w/ Cord Complete Assembly	1				ZPS001311000		
8	Holder plate B	1				ER2AS9485		
9	Cable Packing C12	1				E2D525125		
10	Warning Tag PB	1				SWJ9013AV		
11	Tag Holder	1				E3S787003		
12	Pendent Assembly	1				SWPH100AD		
13	E-Stop Button and Switch Assembly	1				SWD9024AA		
14	Machine Screw w/Spring Washer	1				J1AP24002608		
15	Nut	1				9093414		
16	Pendant Cable	ft				18/5P		
17	Pan Head Machine Screw w/ Spring Washer	4				MS554010		
18	Cable Clamp	2				ER2AS9559		
19	Pan Head Machine Screw w/ Spring Washer	3				MS556010		

9.5 Nameplates and Warning Labels

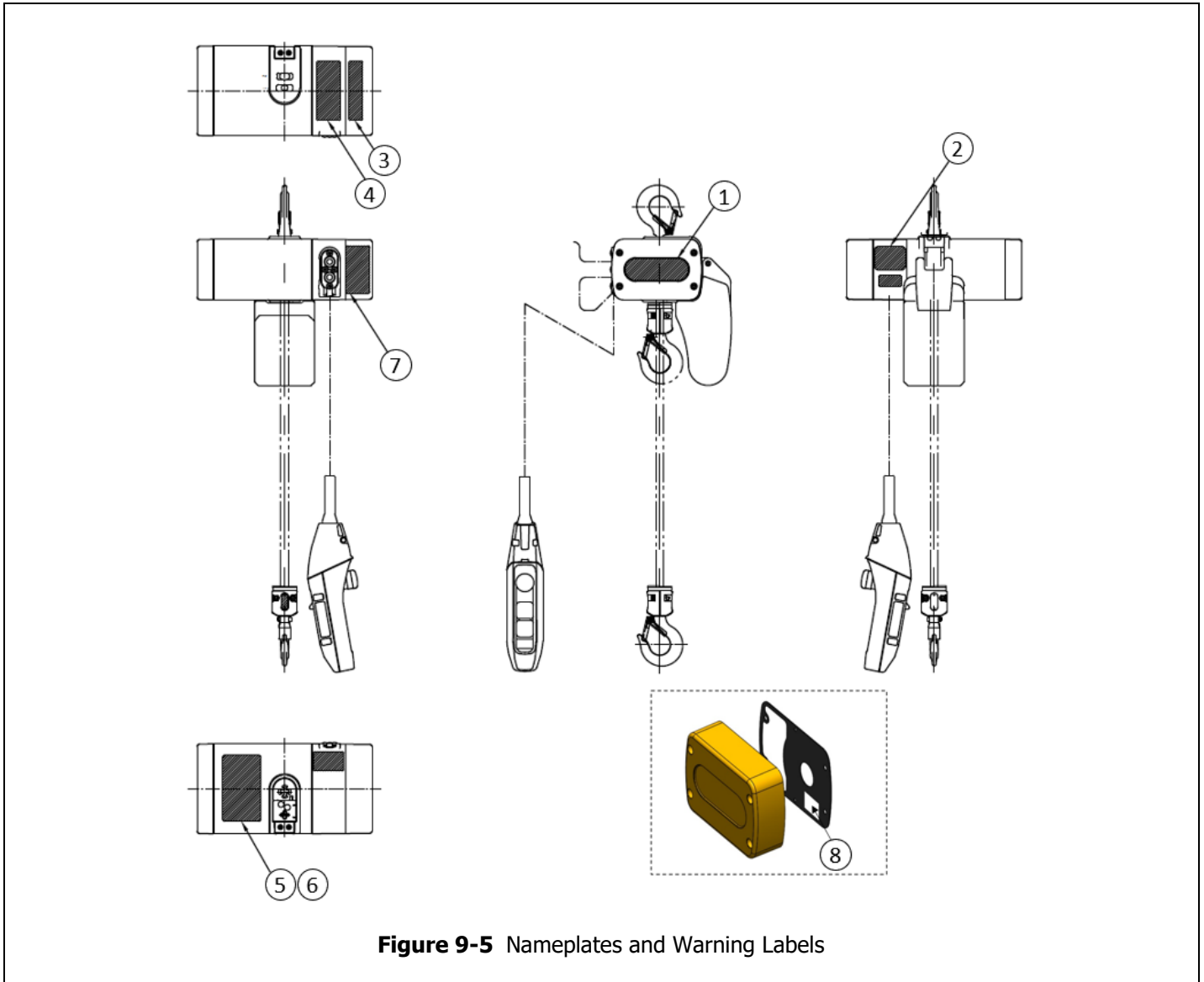

Figure 9-5 Nameplates and Warning Labels

Figure No.	Part Name	Parts Per Hoist	EM001S	EM003L	EM005C	SEM003L	SEM005C
1	Name Plate B	1	80743				
2	Name Plate D	1	80745	80746	80747	80746	80747
3	Warning Label HW	1	ER2CI9806				
4	Warning Label E	1	ER2CS9936				
5	Name Plate SP	1	ER2DHE01S9B6				
6	Sticker SP	1			8075101		
7	Check Phase and Voltage Label	1	80767	80767	80767	80767	80767
8	QR Code Label	1	8076104 (To Wiring Diagram 81887)			8076105 (To Wiring Diagram 81904)	

This Page Intentionally Left Blank

This Page Intentionally Left Blank



Harrington Hoists, Inc.
401 West End Avenue
Manheim, PA 17545

www.harringtonhoists.com

Toll Free: 800-233-3010
Phone: 717-665-2000
Fax: 717-665-2861

© HARRINGTON HOISTS, INC.
ALL RIGHTS RESERVED

EM-SEMOM-ENG