



Read this Owner's Manual thoroughly before operating the equipment. Keep it with the equipment at all times. Replacements are available from Thern, Inc., PO Box 347, Winona, MN 55987, 507-454-2996. www.thern.com

IMPORTANT: Please record product information on page 2. This information is required when calling the factory for service.



Owner's Manual

For
5110 and 5124 Series
Portable Davit Cranes

Two-Year Limited Warranty

Please record the following:

Date Purchased: _____

Crane Model No.: _____

Crane Serial No.: _____

If sold with a winch:

Winch Model No.: _____

Winch Serial No.: _____

This information is required when calling the factory for service.

Thern, Inc. warrants its products against defects in material or workmanship for two years from the date of purchase by the original using buyer, or if this date cannot be established, the date the product was sold by Thern, Inc. to the dealer. To make a claim under this warranty, contact the factory for an RGA number. The product must be returned, prepaid, directly to Thern, Inc., 5712 Industrial Park Road, Winona, Minnesota 55987. The following information must accompany the product: the RGA number, the date of purchase, the description of the claimed defect, and a complete explanation of the circumstances involved. If the product is found to be defective, it will be repaired or replaced free of charge, and Thern, Inc. will reimburse the shipping cost within the contiguous USA.

This warranty does not cover any damage due to accident, misuse, abuse, or negligence. Any alteration, repair or modification of the product outside the Thern, Inc. factory shall void this warranty. This warranty does not cover any costs for removal of our product, downtime, or any other incidental or consequential costs or damages resulting from the claimed defects. This warranty does not cover brake discs, wire rope or other wear components, as their life is subject to use conditions which vary between applications.

FACTORY AUTHORIZED REPAIR OR REPLACEMENT AS PROVIDED UNDER THIS WARRANTY IS THE EXCLUSIVE REMEDY TO THE CONSUMER. THERN, INC. SHALL NOT BE LIABLE FOR ANY INCIDENTAL OR CONSEQUENTIAL DAMAGES FOR BREACH OF ANY EXPRESS OR IMPLIED WARRANTY ON THIS PRODUCT. EXCEPT TO THE EXTENT PROHIBITED BY APPLICABLE LAW, ANY IMPLIED WARRANTY OF MERCHANTABILITY OR FITNESS FOR A PARTICULAR PURPOSE ON THIS PRODUCT IS LIMITED IN DURATION TO THE DURATION OF THIS WARRANTY.

Some states do not allow the exclusion or limitation of incidental or consequential damages, or allow limitations on how long an implied warranty lasts, so the above limitation or exclusion may not apply to you. This warranty gives you specific legal rights, and you may also have other rights which vary from state to state.

Note: Thern, Inc. reserves the right to change the design or discontinue the production of any product without prior notice.

About This Manual

The Occupational Safety and Health Act of 1970 states that it is the employer's responsibility to provide a workplace free of hazard. To this end, all equipment should be installed, operated, and maintained in compliance with applicable trade, industrial, federal, state, and local regulations. It is the equipment owner's responsibility to obtain copies of these regulations and to determine the suitability of the equipment to its intended use.

This Owner's Manual, and warning labels attached to the equipment, are to serve as guidelines for hazard-free installation, operation, and maintenance. They should not be understood to prepare you for every possible situation.

The information contained in this manual is applicable only to the Thern 5110 and 5124 Series Portable Davit Cranes. Do not use this manual as a source of information for any other equipment.

The following symbols are used for emphasis throughout this manual:

▲WARNING

Failure to follow 'WARNING!' instructions may result in equipment damage, property damage, and/or serious personal injury.

▲CAUTION

Failure to follow 'CAUTION!' instructions may result in equipment damage, property damage, and/or minor personal injury.

Important!

Failure to follow 'important!' instructions may result in poor performance of the equipment.

Suggestions for Safe Operation

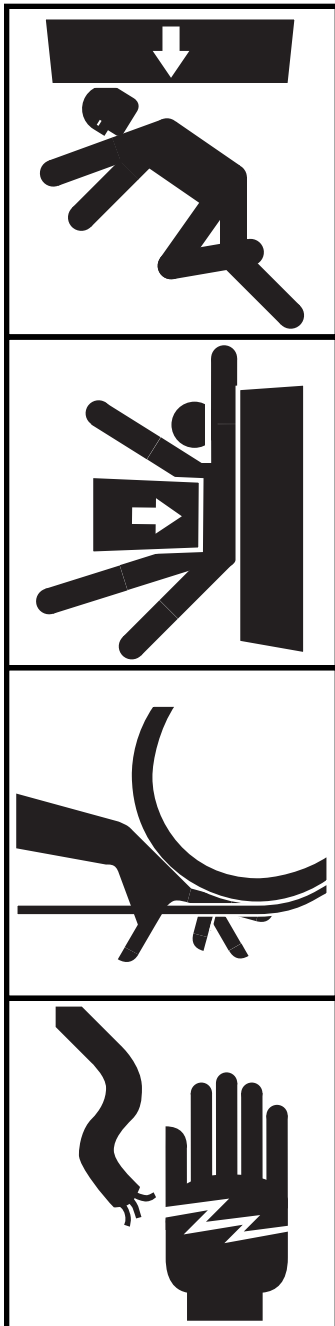

⚠️WARNING

DO the following:

Read and comply with the guidelines set forth in this Owner's Manual. Keep this manual, and all labels attached to the crane, readable and with the equipment at all times. Contact Thern, Inc. for replacements.

Check lubrication before use.

Install the wire rope securely to the winch drum.

Keep at least 4 wraps of wire rope wound on the drum at all times, to serve as anchor wraps. With less than 4 wraps on the drum the wire rope could come loose, causing the load to escape.

Keep hands away from sheaves, gears, wire rope, and other moving parts.

Disconnect electric power before servicing the equipment.

Keep all unnecessary personnel away from crane while in operation. Keep out of the path of the load, and out of the path of a broken wire rope that might snap back and cause injury.

When operating the ratchet jack, avoid un-threading. Test the travel limits of the ratchet jack before assembly to the crane and before loading, to verify it does not un-thread. Contact Thern if it does un-thread.

DO NOT do the following:

Do not lift people, or things over people. Do not walk or work under a load or in the line of force of any load.

Do not exceed the load rating of the crane or any other component in the system. To do so could result in failure of the equipment.

Do not use more than one crane to move a load that exceeds the load rating of a single crane. A shift in load weight could overload the equipment.

Do not use damaged or malfunctioning equipment. To do so could result in failure of the equipment.

Do not modify the equipment in any way. To do so could cause equipment failure.

Do not wrap the wire rope around the load. This damages the wire rope and could cause the load to escape. Use a sling or other approved lifting device.

Do not operate the crane with guards removed or improperly installed.

Do not divert your attention from the operation. Stay alert to the possibility of accidents, and try to prevent them from happening.

Do not jerk or swing the load. Avoid shock loads by starting and stopping the load smoothly. Shock loads overload the equipment and may cause damage.

Do not use the crane and winch components for any use other than for their original intended function.

Do not use the crane to drag or pull loads. This will create side pulls, which could damage the equipment or cause the load to tip.

Do not leave a suspended load unattended. Place the load on the ground if it must be left unattended.

Do not adjust the winch brake with the load suspended.

Do not force the ratchet handle past travel limits. This could shear the travel stop pin and cause damage or injury.

1.1 Installing the Crane

Important!

- A qualified professional should inspect or design the foundation to insure that it will provide adequate support.
- Locate the crane so it will be visible during the entire operation.

⚠WARNING

Do not install the crane in an area defined as hazardous by the National Electric Code, unless installation in such an area has been thoroughly approved.

Do not install the crane near corrosive chemicals, flammable materials, explosives, or other elements that may damage the crane or injure the operator. Adequately protect the crane and the operator from such elements.

Position the crane so the operator can stand clear of the load, and out of the path of a broken wire rope that could snap back and cause injury.

Attach the crane to a rigid and level foundation that will support the crane and its load under all load conditions, including shock loading.

1.1.1 CONSULT APPLICABLE CODES AND REGULATIONS for specific rules on installing the equipment.

1.1.2 LOCATE THE CRANE in an area clear of traffic and obstacles that could interfere with operation. Make sure the crane is accessible for maintenance and operation.

1.1.3 INSTALL THE CRANE on a level surface. **An uneven surface may cause the boom to rotate in the direction the mast is leaning.**

1.1.4 FASTEN THE BASE securely to the foundation to withstand applicable overturning moments and mounting bolt reaction. See Table 1.

a FOR STANDARD PRODUCTS referred to in this manual, use 5/8 - inch coarse thread fasteners, grade 5 or better. Torque for Grade 5 fasteners without lubrication is 150 ft lb. Make sure mounting holes are secured to a solid foundation able to support the crane and the load under all conditions with design factors based on accepted engineering practices.

b NON-STANDARD PRODUCTS that vary from the original design may have different fastening requirements. Contact a structural engineer or Thern, Inc. for this information.

TO COMPLY WITH LOCAL CODES, CONTACT A QUALIFIED PROFESSIONAL TO OBTAIN PROPER STRUCTURE OR FOUNDATION SPECIFICATIONS FOR THE MOUNTING OF THERN PRODUCTS.

Table 1 – Crane Reactions

Crane Model	Mast Moment	Suggested Bolt Size	Pedestal Base Only	Wall-Mount Base Only	
			Axial Force ¹	Axial Force ¹ Per Bolt	Shear Force Per Bolt
5110	37,817 in-lb	5/8 inch	1,844 lb	1,304 lb	1,177 lb
5124	95,236 in-lb	5/8 inch	4,644 lb	3,284 lb	2,781 lb

¹ Force in tension

1.2 Assembling the Crane

Important!

- Inspect the crane during assembly according to the Instructions for Periodic Inspection. This will give you a record of the condition of the crane with which to compare future inspections.
- Save all boxes and crates that the crane was shipped in, use them again if you need to repack the crane.
- Contact the factory immediately if any parts are missing or damaged.
- Do not overtighten fasteners, this may strip threads or cause damage to other parts.

Figure 1 – Cotter Pins

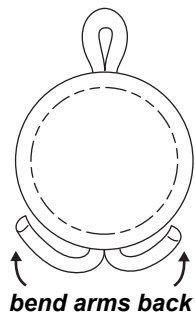

⚠ CAUTION

When installing the ratchet jack, support the end of the boom so the boom does not fall and the ratchet jack does not swing up causing damage or injury.

When installing the boom extension, hold the boom extension securely so it does not slide abruptly in or out of the boom causing damage or injury.

- 1.2.1 STUDY PARTS DRAWINGS to understand how the crane is assembled. See pages 18-22.
- 1.2.2 LUBRICATE PINS and other components prior to assembly. See Section 3.3 Lubricating the Crane.
- 1.2.3 INSTALL THE BASE and then assemble the crane in the following order.
 - a INSTALL THE MAST in the base. Move the mast side to side to make sure the bottom of the mast properly seats on the pin in the bottom of the base.
 - b FASTEN THE BOOM to the mast using the clevis pin and lynch pin provided. **Make sure the boom is positioned correctly, with the carrying handles located on the same side as the handles on the mast.**
 - c INSTALL THE RATCHET JACK by fastening one end of the ratchet jack to the ears on the boom with the clevis and lynch pin provided. Carefully pivot the boom up until the other end of the ratchet jack aligns with the ears on the mast, and secure the ratchet jack to the mast using the clevis pin and lynch pin provided.
 - d ADJUST THE BOOM with the ratchet jack so the boom is slightly above the lowest boom angle. See Figures 4a and 4b. **Do not lower boom below the lowest point, or the boom could fall and may result in the load escaping.**
 - e SLIDE THE BOOM EXTENSION into the boom, and secure in place with the clevis pin and lynch pin provided. **Make sure the boom extension is positioned correctly with the boom ears positioned up. See assembly drawings.**
 - f POSITION THE SHEAVE between the ears on the boom extension, and fasten in place with the clevis pin and cotter pin provided.
 - g INSTALL THE CLEVIS PIN in the holes located above the sheave at the end of the boom. Secure in place with the hair cotter pin provided.
 - h INSTALL THE HANDLE on the lower end of the boom, using the clevis pin and lynch pin provided.
- 1.2.4 FASTEN THE WINCH to the mounting plate on the boom using the fasteners provided. On some models you will need to use the winch adapter plate and fasteners provided to fasten the winch to the crane. **Make sure the winch is positioned correctly with the winch drum facing forward toward the boom extension.**
- 1.2.5 INSTALL THE WINCH HANDLE on hand winches, or connect electric current on power winches. Refer to instructions in the Winch Owner's Manual.
- 1.2.6 INSTALL THE WIRE ROPE. Use **wire rope assemblies in the length specified on page 23.**
 - a PASS THE WIRE ROPE over the sheave at the end of the boom.
 - b ANCHOR THE WIRE ROPE to the winch drum and wind 4 wraps of wire rope onto the drum to act as anchor wraps. Refer to the instructions in the Winch Owner's Manual.
- 1.2.7 MAKE SURE ALL LYNCH PINS ARE PROPERLY INSTALLED, and cotter pins properly bent to secure them in place. See Figure 1.

2.1 General Theory of Operation

Important!

- Limit nonuniform winding by keeping tension on the wire rope.
- It is your responsibility to detect and account for different factors affecting the condition and performance of the equipment.

- 2.1.1 THE FORCE REQUIRED to lift the load must not exceed the load rating of the crane. Consider the total force required to lift the load, not the weight of the load.
- 2.1.2 THIS EQUIPMENT CAN develop forces that will exceed the load rating. It is the responsibility of the equipment user to limit the size of the load. Inspect the equipment regularly for damage according to the instructions contained in this manual.
- 2.1.3 PERFORMANCE RATINGS of the equipment are affected by the position of the boom, the amount of wire rope you use and whether you use a single or two part line. Two-part line not available on the 5110 Series. See the Performance Characteristics Tables on page 23.
- a LOAD RATING represents the maximum force that can be placed on new equipment. Load ratings are assigned values for specific boom positions, wire rope lengths, and rigging configurations (single or two part line). **Crane load ratings decrease as you extend the boom, and increase with two-part line. Two-part line not available on 5110 Series. See the Performance Characteristics Tables page 23.**
- b LIFT varies with the position of the boom, the length of the wire rope, and the rigging configuration (single or two part line). Two-part line not available on the 5110 Series.
- c REACH varies with the position of the boom.
- 2.1.4 DUTY RATINGS refer to the type of use the equipment is subject to. Consider the following when determining duty rating.
- a ENVIRONMENT: harsh environments include hot, cold, dirty, wet, corrosive, or explosive surroundings. **Protect the equipment from harsh environments when possible.**
- b MAINTENANCE: poor maintenance, meaning poor cleaning, lubrication, or inspection, leads to poor operation and possible damage of the equipment. **Minimize poor maintenance by carefully following the instructions contained in this manual.**
- c LOADING: severe loading includes shock loading and lifting loads that exceed the load rating of the equipment. **Avoid shock loads, and do not exceed the load rating of the equipment.**
- d FREQUENCY OF OPERATION: frequent or lengthy operations increase wear and shorten the life span of gears, bearings, sheaves, and other components. **Increase maintenance of the equipment if used in frequent operations.**

CONTACT THE FACTORY FOR MORE INFORMATION.

2.2 Preparing for Operation

Important!

- Start an inspection program as soon as you put the crane into use.
- Appoint a qualified person to be responsible for regularly inspecting the equipment.
- Keep written records of inspection. This allows comparison with comments from previous inspections so you can see changes in condition or performance.

⚠WARNING

When operating the ratchet jack, avoid un-threading. Test the travel limits of the ratchet jack before assembly to the crane and before loading, to verify it does not un-thread. Contact Thern if it does un-thread.

Do not force the ratchet handle past travel limits. This could shear the travel stop pin and cause damage or injury.

⚠CAUTION

When adjusting boom length, set the boom angle just above the lowest angle and hold the boom extension securely so it does not slide abruptly in or out of the boom causing damage or injury. See Figures 4a and 4b.

When adjusting the boom angle, raise the rotation handle with one hand and operate the ratchet jack with the other to avoid jamming the handles and causing damage or injury.

Figure 2 – Positioning the Boom

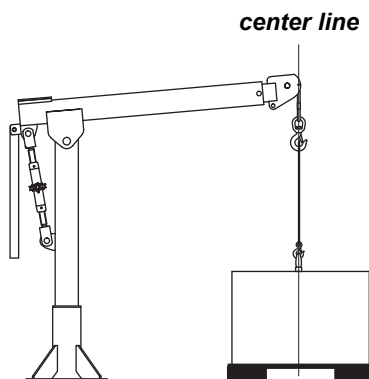

correct

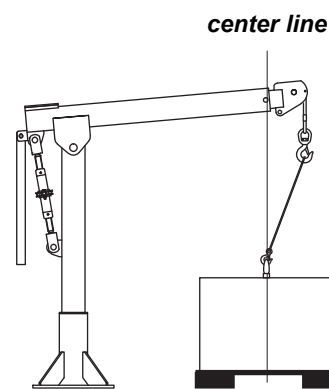

incorrect

- 2.2.1 CONSIDER THE OPERATION. Do not begin until you are sure you can perform the entire operation without hazard.
- 2.2.2 INSPECT ALL COMPONENTS of the system.
- INSPECT THE CRANE and other equipment according to the Instructions for Frequent Inspection.
 - INSPECT THE WINCH according to the instructions in the Winch Owner's Manual.
 - OPERATORS must be in good health, alert, thoroughly trained in operating the equipment, and properly clothed (hard hat, safety shoes and safety glasses, no loose clothing).
 - THE LOAD must be clear of other objects and free to move. Make sure the load will not tip, spin, roll away, or in any way move uncontrollably.
- 2.2.3 KNOW YOUR LOAD and make sure you do not exceed the load rating of the crane or any other equipment in the system.
- 2.2.4 POSITION THE BOOM so the load hook is centered over the load. **Avoid side pulls which could damage the crane or cause the load to tip. See Figure 2.**
- ADJUST BOOM LENGTH by moving the boom extension in or out. **The load rating decreases as you increase boom length. See the Performance Characteristics Tables page 23.**
 - ADJUST BOOM ANGLE by operating the ratchet jack to raise or lower the boom. **The lift height below base level decreases as you raise the boom. See the Performance Characteristics Tables page 23.**
- 2.2.5 CONFIGURE THE CRANE for single part or two-part line operation. **Load ratings may increase with two-part line, lift height below base level will decrease with two part line. Two part line not available on 5110 Series. See the Performance Characteristics Tables page 23.** Study parts drawings on pages 18-22.

2.3 Attaching the Load

⚠WARNING

Do not wrap the wire rope around the load. This damages the wire rope and could cause the load to escape. Use a sling or other approved lifting device.

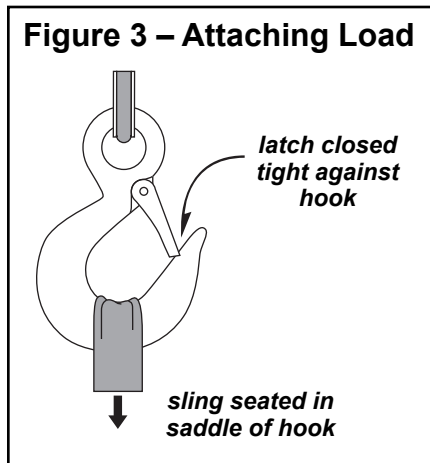

- 2.3.1 CLEAR OBJECTS from the path of the load so you can move it freely and observe it at all times during the operation.
- 2.3.2 MAKE SURE THE WIRE ROPE is not twisted. A twisted wire rope could cause the load to spin when it is raised off the ground.
- 2.3.3 ATTACH THE LOAD using a nylon sling, or other approved lifting device. Follow the recommendations of the sling manufacturer.
- SEAT THE SLING in the saddle of the hook with the hook latch completely closed. See Figure 3.
 - CENTER THE LOAD on the hook so it will remain balanced and not tip or rotate to one side.

2.4 Moving the Load

⚠WARNING

When operating the ratchet jack, avoid un-threading. Test the travel limits of the ratchet jack before assembly to the crane and before loading, to verify it does not un-thread. Contact Thern if it does un-thread.

Do not force the ratchet handle past travel limits. This could shear the travel stop pin and cause damage or injury.

- 2.4.1 MOVE THE LOAD slowly and smoothly, only a small distance at first. Make sure the load is balanced and securely attached before continuing.
- 2.4.2 OPERATE THE WINCH to raise or lower the load. Refer to the instructions in the Winch Owner's Manual.
- 2.4.3 OBSERVE THE WIRE ROPE as it winds onto the drum. If it becomes loose, uneven, or overlapped, stop the operation and rewind the wire rope before continuing. **Continued operation with overlapped or uneven wire rope can damage the wire rope and shorten its life.**
- 2.4.4 OPERATE THE RATCHET JACK if necessary, to adjust the angle of the boom to keep the sheave centered over the load.
- 2.4.5 ROTATE THE BOOM to move the load side-to-side.
- ROTATE THE BOOM slowly and smoothly to avoid swinging the load or causing shock loads. **Do not jam the boom against other objects.**
 - USE THE HANDLE to rotate the boom. **Do not push or pull the load or the wire rope to rotate the boom.**

Important!

- Obey a stop signal from anyone.
- Maintain tension on the wire rope to keep it tightly and evenly wound on the drum.
- If the crane and load are not visible during the entire operation, get help from another person.
- Appoint a supervisor if more than one person is involved in the operation. This will reduce confusion and increase safety.
- When lifting a load, use a tag line to keep the load from swinging or twisting, while keeping yourself away from the load.

Figure 4a – Lowest Boom Angle - 5110

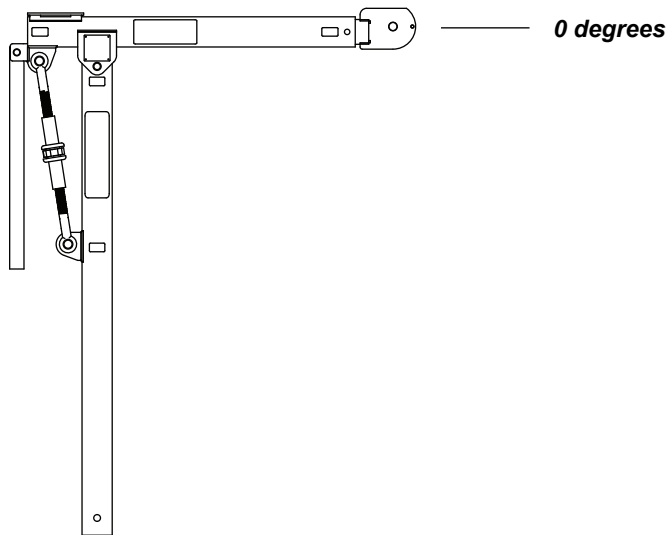
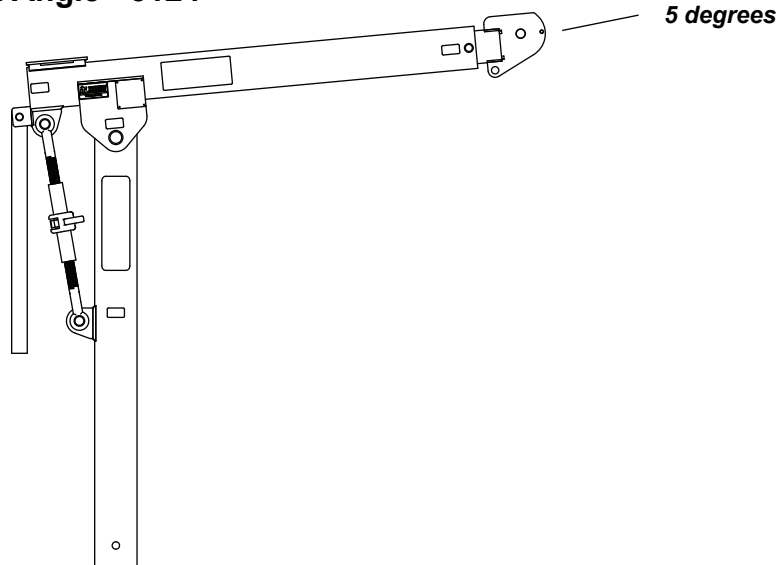

Figure 4b – Lowest Boom Angle - 5124



3.1 **Cleaning the Crane**

Important!

Increase the frequency of maintenance procedures if the crane is:

- Operated for long periods.
- Used to lift heavy loads.
- Operated in wet, dirty, hot, or cold surroundings.

Clean the crane to remove dirt and help prevent rust and corrosion.

3.1.1 **CLEAN THE CRANE** every six months or whenever it is dirty.

- a **WIPE ALL EQUIPMENT** to remove dirt and grease.
- b **LEAVE A LIGHT FILM** of oil on all surfaces to protect against rust and corrosion.
- c **WIPE OFF** excessive amounts of oil to avoid the accumulation of dirt.

3.1.2 **REMOVE UNNECESSARY OBJECTS** from the area surrounding the crane.

3.2 Disassembling the Crane

⚠CAUTION

When removing the boom extension, hold the boom extension securely so it does not slide abruptly in or out of the boom causing damage or injury.

When removing the ratchet jack, support the end of the boom so the boom does not fall and the ratchet jack does not swing up causing damage or injury.

- 3.2.1 REMOVE ANY ATTACHED LOAD from the wire rope.
- 3.2.2 REMOVE THE WIRE ROPE
 - a REMOVE THE ROPE KEEPER CLEVIS PIN located at the end of the boom.
 - b UNWIND THE ROPE from the winch drum and release the anchor.
 - c REPLACE THE ROPE KEEPER CLEVIS PIN
- 3.2.3 REMOVE THE WINCH HANDLE on hand winches, or disconnect electric current on power winches. Refer to instructions in the Winch Owner's Manual.
- 3.2.4 REMOVE THE WINCH from the mounting plate.
 - a SECURE THE WINCH to prevent it from falling off when the fasteners are loosened.
 - b LOOSEN AND REMOVE the fasteners.
- 3.2.5 REMOVE THE ROTATION HANDLE from the back of the boom. (NOTE: Remove the rotation handle first before the ratchet jack to avoid it swinging up if the boom should fall when the ratchet jack is released)
 - a REMOVE THE LYNCH PIN and clevis pin and remove the handle.
 - b REPLACE THE CLEVIS PIN and lynch pin.
- 3.2.6 REMOVE THE BOOM EXTENSION.
 - a ADJUST THE BOOM ANGLE using the ratchet jack, so the boom is just slightly above horizontal.
 - b SECURE THE BOOM EXTENSION then remove the lynch pin and clevis pin securing the boom extension to the boom.
 - c CAREFULLY PULL THE BOOM EXTENSION out of the boom, then reinstall the clevis pin and lynch pin in the boom.
- 3.2.7 REMOVE THE RATCHET JACK.
 - a SECURE THE BOOM to prevent it from falling when the ratchet jack is released.
 - b DISCONNECT THE RATCHET JACK at the mast ears (bottom) by removing the lynch pin and clevis pin and slowly lower the boom until it is resting against the mast. Be careful that the ratchet jack does not swing up and cause injury.
 - c REMOVE THE PINS AT THE BOOM (top) to disconnect the ratchet jack from the crane. Hold onto the ratchet jack to prevent it from falling away.

- d RECONNECT the clevis pins to the boom and mast with the appropriate lynch pins.
- 3.2.8 DISCONNECT THE BOOM from the mast.
- a SECURE THE BOOM to prevent it from falling away when the pins are removed.
 - b REMOVE THE LYNCH PIN AND CLEVIS PIN and carefully remove the boom.
 - c REPLACE the clevis pin and lynch pin in the mast.
- 3.2.9 REMOVE THE MAST FROM THE BASE, by lifting it out of the base.

TO REASSEMBLE THE CRANE, SEE ASSEMBLING THE CRANE, SECTION 1.2.

3.3 Lubricating the Crane

Important!

- Make sure lubricant has a temperature rating appropriate for the ambient temperatures of the operation.

Lubricate the crane properly to help protect it from wear and rust. Read the following instructions carefully.

- 3.3.1 LUBRICATE ALL PINS before installation and at least every 3 months. Use a grease brush to apply a light film of NLGI #2 grease to all pins.
- 3.3.2 LUBRICATE THE MAST BEARING before installation and at least every 3 months. Use a grease brush to apply a film of NLGI #2 grease to both inside and outside surfaces.
- 3.3.3 LUBRICATE THE PIN BUSHING located on the bottom of the mast before installation and at least every 3 months. Use a grease brush to apply a film of NLGI #2 grease to the bushing.
- 3.3.4 LUBRICATE THE RATCHET JACK before installation and at least every 3 months. Use a grease gun to apply an NLGI #2 grease to the grease fittings on the ratchet jack until excess grease can be seen.
- 3.3.5 LUBRICATE THE WINCH. Refer to the Winch Owner's Manual for instructions.
- 3.3.6 LUBRICATE THE WIRE ROPE and other equipment by following the manufacturers recommendations.

3.4 Inspecting the Equipment

Important!

- Start an inspection program as soon as you put the crane into use.
- Appoint a qualified person to be responsible for regularly inspecting the equipment.
- Keep written records of inspection. This allows comparison with comments from previous inspections so you can see changes in condition or performance.

Perform frequent inspections:

- Before each operation.
- Every 3 hours during operation.
- Whenever you notice signs of damage or poor operation.

Frequent Wire Rope Inspection:

- Use ASME B30.7 as a guideline for rope inspection, replacement and maintenance.
- Check the wire rope, end connections and end fittings for corrosion, kinking, bending, crushing, bird-caging or other signs of damage.
- Check the number, distribution and type of visible broken wires. See paragraph 3.3.4 b and Figure 5.
- Check the wire rope for reduction of rope diameter from loss of core support, or wear of outside wires. See Figure 7.
- Take extra care when inspecting sections of rapid deterioration such as sections in contact with saddles, sheaves, repetitive pickup points, crossover points and end connections.

⚠WARNING

Do not use damaged or malfunctioning equipment. Place an “OUT OF ORDER” sign on the crane. Do not use the crane until the sign is removed by a qualified maintenance person who has completely corrected the problem.

Inspect the crane to detect signs of damage or poor operation before they become hazardous. See Table 2 Inspection Checklist.

3.4.1 CONSULT APPLICABLE CODES AND REGULATIONS for specific rules on inspecting the crane and other equipment.

3.4.2 REFER TO THE WINCH OWNER’S MANUAL for information regarding winch inspection.

3.4.3 Instructions for Frequent Inspection

a VISUALLY INSPECT the entire crane and all other equipment involved in the operation.

- Check all equipment for cracks, dents, bending, rust, wear, corrosion and other damage.
- Make sure the wire rope is installed correctly and anchored securely.
- Make sure the entire crane is properly lubricated.
- Make sure all fasteners are tight and secure.
- Make sure mounting fasteners are tightened securely.
- Check the ratchet jack for signs of leakage or damage, and make sure it operates smoothly to raise and lower the boom.
- Make sure the foundation is in good condition, and capable of supporting the crane and its load under all load conditions.

b TEST CRANE PERFORMANCE by operating the crane with a load not exceeding the load rating.

- Listen for unusual noises, and look for signs of damage as you operate the crane.
- Make sure the wire rope winds evenly and tightly onto the drum. If it is loose or uneven, rewind it before continuing.
- Make sure the load moves smoothly, without hesitation or strain.
- On hand operated models, make sure the winch handle rotates freely in both directions.
- On power operated models, make sure the winch responds to the control device. It must rotate as shown on the control labels, and it must turn off when you release the control.
- Make sure the boom rotates freely when you push the handle, and remains stationary when you release it.
- Check the brake. Raise the load, then lower it and stop it a few feet off the ground. If the load continues to coast or creep under normal operating conditions, the brake may be worn and in need of repair or replacement. Contact the factory.

Completely correct all problems before continuing. Use the Troubleshooting Chart to help determine the cause of certain problems. See Table 3.

Table 2 – Inspection Checklist

checked boxes indicate damage or problem in need of repair

	damages	problems
general	<input type="checkbox"/> finish weathered, flaking, otherwise damaged <input type="checkbox"/> parts cracked, bent, rusted, worn, otherwise damaged	<input type="checkbox"/> equipment not properly lubricated <input type="checkbox"/> unusual noises, other signs of malfunction
foundation	<input type="checkbox"/> loose, unstable, otherwise damaged	<input type="checkbox"/> not level - boom swerves
fasteners	<input type="checkbox"/> stripped threads, bent, worn, otherwise damaged	<input type="checkbox"/> loose, not tightened to the proper torque
boom assembly	<input type="checkbox"/> holes worn, distorted, or otherwise damaged	<input type="checkbox"/> does not rotate freely
winch assembly	<input type="checkbox"/> gears, bearings, and other parts worn, otherwise damaged	<input type="checkbox"/> winch jerks or hesitates under load
	<input type="checkbox"/> brake corroded, cracked, worn, otherwise damaged	<input type="checkbox"/> brake does not operate properly
sheaves	<input type="checkbox"/> holes worn, distorted, or otherwise damaged	<input type="checkbox"/> does not rotate freely
wire rope	<input type="checkbox"/> bent, crushed, otherwise damaged	<input type="checkbox"/> wire rope loosely or unevenly wound
	<input type="checkbox"/> broken wires, see Figure 5 replace if more than 6 wires in one lay, or 3 wires in one strand in one lay, are broken	number per strand = _____ number per lay = _____
	<input type="checkbox"/> diameter reduced, see Figure 7 replace if diameter is excessively worn	diameter = _____
end connections	<input type="checkbox"/> corroded, rusted, worn, otherwise damaged	<input type="checkbox"/> not securely attached
load hook	<input type="checkbox"/> twisted, bent, worn, otherwise damaged, see Figure 6 replace if twist is 10 degrees or more replace if throat width is 15% larger than nominal replace if thickness is 10% less than nominal	<input type="checkbox"/> hook latch fails to close when released twist = _____ throat width = _____ thickness = _____
labels and plates	<input type="checkbox"/> dirty, illegible, otherwise damaged	<input type="checkbox"/> loosely attached or missing

comments:

authorized signature: _____ date _____

Perform periodic inspections:

- Every 6 months.
- Whenever you return the crane to service from storage.
- Whenever you notice damage or poor operation in a frequent inspection.
- Whenever you have, or think you may have, overloaded or shock loaded the crane.

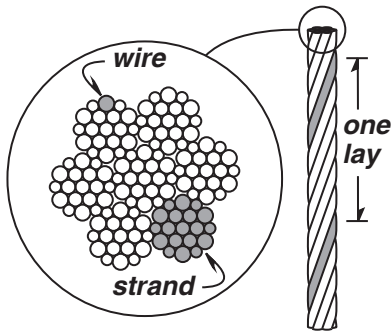
Figure 5 – Broken Wires

Wire rope assembly must be replaced if more than 6 wires are broken in one lay, or if more than 3 wires are broken in one strand in one lay.

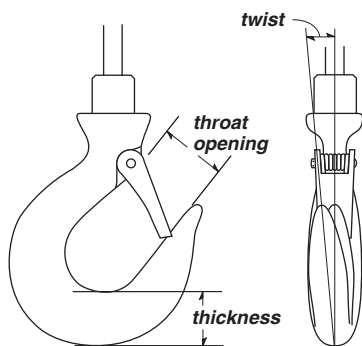
Figure 6 – Load Hook Inspection

The wire rope assembly must be replaced if the throat opening is 15% wider than nominal, if the thickness is 10% less than nominal, or if the hook is twisted 10° or more.

3.4.4 Instructions for Periodic Inspection

- VISUALLY INSPECT** the crane and all other equipment.
 - Check the finish for wear, flaking, or other damage.
 - Check all equipment for cracks, dents, bending, rust, wear, corrosion and other damage. If the equipment was overloaded, or if you notice cracks and other signs of overloading and damage, promptly remove equipment from use and have it repaired or replaced. **DO NOT CONTINUE TO USE DAMAGED OR OVERLOADED EQUIPMENT OR WIRE ROPE.**
 - Check all fasteners for stripped threads, wear, bending, and other damage.
 - Make sure the entire crane is properly lubricated.
 - Check the ratchet jack for signs of leakage or damage, and make sure it operates smoothly to raise and lower the boom.
 - Make sure all labels and plates are readable, firmly attached, free of damage and clean. Replacements are available from the factory.
- REMOVE THE WIRE ROPE** entirely from the crane.
 - Always wear protective clothing when handling wire rope.
 - Check the entire length of wire rope for bent wires, crushed areas, broken or cut wires, corrosion, and other damage. Carefully inspect areas that pass over sheaves or through roller guides.
 - Note the location and concentration of broken wires. Replace wire rope if more than 6 wires are broken in one lay, or more than 3 wires are broken in one strand in one lay. See Figure 5.
 - Make sure the load hook or other device is securely attached to the wire rope, and the wire rope where it is attached is not frayed, corroded, broken, or otherwise damaged.
 - Measure the throat opening, thickness, and twist of the hook. Replace the hook if it shows signs of damage. See Figure 6.
 - Make sure hook latch opens without binding and closes when released.
 - Check the anchor holes in the drum and the surrounding area for signs of wear or distortion.
- PLACE** enough weight to keep the wire rope straight and tightly drawn.
 - Measure the diameter of the wire rope, especially in areas where wear is noticeable. Replace the wire rope if the diameter measures below the minimum diameter at any point. See Figure 7.
- REMOVE THE WINCH** and inspect it by following the instructions in the Winch Owner's Manual.
- DISASSEMBLE THE CRANE** by removing the ratchet jack, the boom, and the winch. Inspect each component for damage.
- REMOVE THE CRANE BASE** from the foundation.
 - Check fasteners for stripped threads, wear, bending, and other damage.
 - Check the foundation for cracks, corrosion, and other damage.

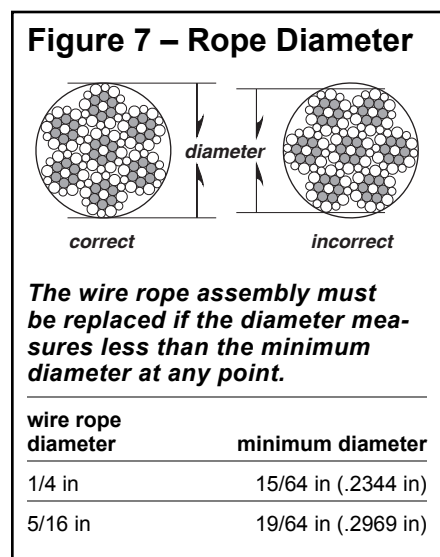

- g FASTEN THE CRANE BASE securely to the foundation.
- h REASSEMBLE THE CRANE.
- i TEST CRANE PERFORMANCE by operating the crane with a load equal to the load rating.
 - Listen for unusual noises, and look for signs of damage as you operate the crane.
 - Make sure the wire rope winds evenly and tightly onto the drum. If it is loose or uneven, rewind it before continuing.
 - Make sure the load moves smoothly, without hesitation or strain.
 - On hand operated models, make sure the winch handle rotates freely in both directions.
 - On power operated models, make sure the winch responds to the control device. It must rotate as shown on the control labels, and it must turn off when you release the control.
 - Make sure the boom rotates freely when you push the handle, and remains stationary when you release it.
 - Check the brake. Raise the load, then lower it and stop it a few feet off the ground. If the load continues to coast or creep under normal operating conditions, the brake may be worn and in need of repair or replacement. Contact the factory.

Completely correct all problems before continuing. Use the Troubleshooting Chart to help determine the cause of certain problems. See Table 3.

problem	cause	correction
overheating	<ul style="list-style-type: none"> • operated too long without rest. • load too heavy • poor lubrication. • bearing seized up 	<ul style="list-style-type: none"> allow to cool lighten load inspect and lubricate as necessary inspect and replace as necessary
boom bounces up and down	<ul style="list-style-type: none"> • load too heavy • mounting bolts loose • sheave worn or damaged. • foundation loose or unlevel • winch gears worn or damaged 	<ul style="list-style-type: none"> lighten load tighten mounting bolts to proper torque inspect and replace as necessary inspect and repair as necessary inspect and repair as necessary
boom does not rotate	<ul style="list-style-type: none"> • rotation points contaminated or worn • flange bearing broken or locked. 	<ul style="list-style-type: none"> inspect and repair as necessary inspect and replace as necessary
boom rotates on its own	<ul style="list-style-type: none"> • foundation loose or unlevel • mast bent, distorted, or leaning. 	<ul style="list-style-type: none"> inspect and repair as necessary inspect and repair as necessary
unusual noises		
high pitched squeak	• poor lubrication.	lubricate entire crane properly
grinding noise	• contaminated lubricant at rotation points	clean and lubricate rotation points
rattling noise	• loose bolts, set screws or other fasteners.	tighten all bolts and other fasteners
Refer to the Winch Owner's Manual for possible problems with the winch and brake.		

3.5 Repairing the Crane

Important!

- It is your responsibility to determine when to replace parts. When considering whether to continue using a part or to replace it, remember that replacing it is the best way to avoid further equipment damage.
- Appoint a qualified person to be responsible for all repairs to the equipment.

- 3.5.1 GET FACTORY AUTHORIZATION for all repairs. Unauthorized repairs will void the warranty, and may lead to damage or failure of the crane.
- 3.5.2 REPLACE DAMAGED OR POORLY OPERATING PARTS with Thern repair parts.
- 3.5.3 REFINISH AREAS where the paint is worn or flaking. A good finish helps to protect against corrosion and weather damage.
- REMOVE THE FINISH from damaged areas, down to the bare metal.
 - CLEAN THE AREA thoroughly.
 - REPAINT with a high quality primer and finishing coat.
- 3.5.4 TO ORDER REPAIR PARTS, contact your local dealer. Include the following information when ordering:
- model number
 - serial number (or code number)
 - part number
 - date purchased, and from whom
 - description of what happened, or what is wrong
 - your name and return address

Table 4 – Crane Weight Chart

Model 5110

Component	Part Numbers	Component Weight		Assembly/Disassembly Weight (with pins)	
		Standard / Galvanized / Stainless	LB	KG	LB
Mast	C3857RED / C3857GAL / C3834	41	18.5	43	19.35
Boom	D2558RED / D2558GAL / D2553	35	16	37	16.65
Boom Ext	C3858RED / C3858GAL / C3835	25	11.25	26	11.7
Jack	C3410 / C3411 / C3411	11	5	11	5
Handle	B3561RED / B3561GAL / B3834	7	3	7	3
	TOTAL	119	53.75	124	55.7

Model 5124

Component	Part Numbers	Component Weight		Assembly/Disassembly Weight (with pins)	
		Standard / Galvanized / Stainless	LB	KG	LB
Mast	C3385RED / C3385GAL / C3608	66	30	69	31
Boom	D2049RED / D2049GAL / D2270	77	35	80	36
Boom Ext	C3386RED / C3386GAL / C3609	46	21	47	21.2
Jack	C3410 / C3411 / C3411	11	5	11	5
Handle	B3561RED / B3561GAL / B3844	7	3	7	3
	TOTAL	207	94	214	96.2

Winches

Configuration	Part Numbers	LB	KG
M1	M4312PB-K	26	11.8
M2	4WM2-K	36	16.4
M3	M4312PBSS-K	27	12.3
E2	4WP2-K	76	34.5
E4	4777-K	82	37.2
E4DC	4777DC-K	80	36.3

4.1 Transporting the Crane

Important!

- Keep a record of what you ship, and when you send it.

- 4.1.1 PARTIALLY DISASSEMBLE THE CRANE into components that can be transported.
- 4.1.2 PACK THE CRANE for transport, using the original packaging materials, if appropriate.
- 4.1.3 PACK THE WINCH for transport, using the original packaging materials, if appropriate. Please see the winch owner's manual for instructions.
- 4.1.4 REASSEMBLE THE CRANE at its new location following the instructions under Section 1.2 Assembling the Crane.
- 4.1.5 INSPECT THE CRANE according to the Instructions for Frequent Inspection before installing it for operation. See Section 3.4.3 Instructions for Frequent Inspection.

4.2 Storing the Crane

- 4.2.1 PARTIALLY DISASSEMBLE THE CRANE and store all parts in a cool clean place away from corrosive chemicals and moisture.
- 4.2.2 SEAL THE CRANE in plastic with a desiccant to help protect it from rust, corrosion, and other damage.
- 4.2.3 SEAL THE WINCH in plastic with a desiccant to help protect it from rust, corrosion, and other damage. Please see the winch owner's manual for instructions.
- 4.2.4 REASSEMBLE THE CRANE at its new location following the instructions under Assembling the Crane.
- 4.2.5 INSPECT THE CRANE according to Section 3.4.4 Instructions for Periodic Inspection before installing it for operation.

5110 Series Portable Davit Cranes		5110 Series Red Fusibond		5110GAL Series Galvanized Finish		5110SS Series Stainless Steel	
item	description	part number	qty.	part number	qty.	part number	qty.
1	MAST	C3857RED	1	C3857GAL	1	C3834	1
2	BOOM	D2558RED	1	D2558GAL	1	D2553	1
3	BOOM EXTENSION	C3858RED	1	C3858GAL	1	C3835	1
4	COTTER PIN .125 X 1.250	A4305	1	A4305	1	A4305	1
5	CLEVIS PIN .750 X 1.765	A4438	1	A4438	1	A4438	1
6	COTTER PIN .188/.250 X .042 DIA	A6452	1	A6452	1	A6452	1
7	CLEVIS PIN .250 X 1.734	A6905	1	A6905	1	A6905	1
8	SHEAVE ASSEMBLY	B2462	1	B2462	1	B2462	1
9	CLEVIS PIN .500 X 3.766	A8082	1	A8082	1	A8082	1
10	LYNCH PIN	A7256	5	A7256	5	A7256	5
11	CLEVIS PIN .750 X 4.625	A7257	1	A7257	1	A7257	1
12	CLEVIS PIN .906 X 2.875	A7259	2	A7259	2	A7259	2
13	CLEVIS PIN .625 X 2.500	A7260	1	A7260	1	A7260	1
14	RATCHET JACK	C3410	1	C3411	1	C3411	1
15	HANDLE	B3561RED	1	B3561GAL	1	B3844	1
16	WARNING LABEL	A1961	1	A1961	1	A1961	1
17	IMPORTANT INSERT PIN LABEL	A2188	8	A2188	8	A2188	8
18	LOAD RATING LABEL	A8083	1	A8083	1	A8083	1
19	THERN LOGO	A6889	1	A6889	1	A6889	1
20	NAMEPLATE SST	A1976	1	A1976	1	A1976	1

for winch and fasteners
see page 20-21

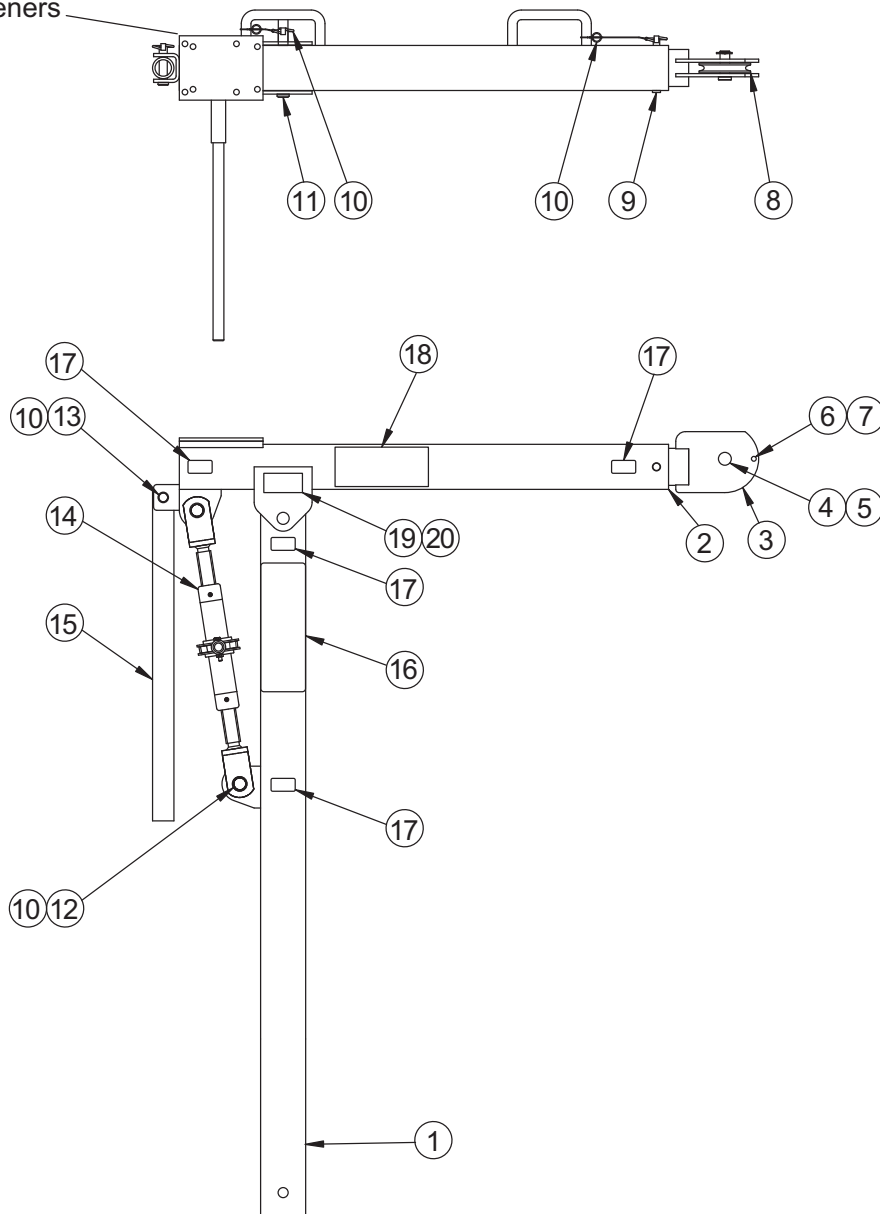

5124 Series Portable Davit Cranes		5124 Series Red Fusibond		5124GAL Series Galvanized Finish		5124SS Series Stainless Steel	
item	description	part number	qty.	part number	qty.	part number	qty.
1	MAST	C3385RED	1	C3385GAL	1	C3608	1
2	BOOM	D2049RED	1	D2049GAL	1	D2270	1
3	BOOM EXTENSION	C3386RED	1	C3386GAL	1	C3609	1
4	COTTER PIN .125 X 1.250	A4305	1	A4305	1	A4305	1
5	CLEVIS PIN .750 X 1.765	A4438	1	A4438	1	A4438	1
6	COTTER PIN .188/.250 X .042 DIA	A6452	1	A6452	1	A6452	1
7	CLEVIS PIN .250 X 1.734	A6631	1	A6631	1	A6631	1
8	SHEAVE ASSEMBLY	B2462	1	B2462	1	B2462	1
9	CLEVIS PIN .750 X 4.625	A7257	1	A7257	1	A7257	1
10	LYNCH PIN	A7256	5	A7256	5	A7256	5
11	CLEVIS PIN 1.250 X 5.500	A7258	1	A7258	1	A7258	1
12	CLEVIS PIN .906 X 2.875	A7259	2	A7259	2	A7259	2
13	CLEVIS PIN .625 X 2.500	A7260	1	A7260	1	A7260	1
14	RATCHET JACK	C3410	1	C3411	1	C3411	1
15	HANDLE	B3561RED	1	B3561GAL	1	B3844	1
16	WARNING LABEL	A1961	1	A1961	1	A1961	1
17	IMPORTANT INSERT PIN LABEL	A2188	8	A2188	8	A2188	8
18	LOAD RATING LABEL	A7261	1	A7261	1	A7261	1
19	THERN LOGO	A6889	1	A6889	1	A6889	1
20	NAMEPLATE SST	A1976	1	A1976	1	A1976	1

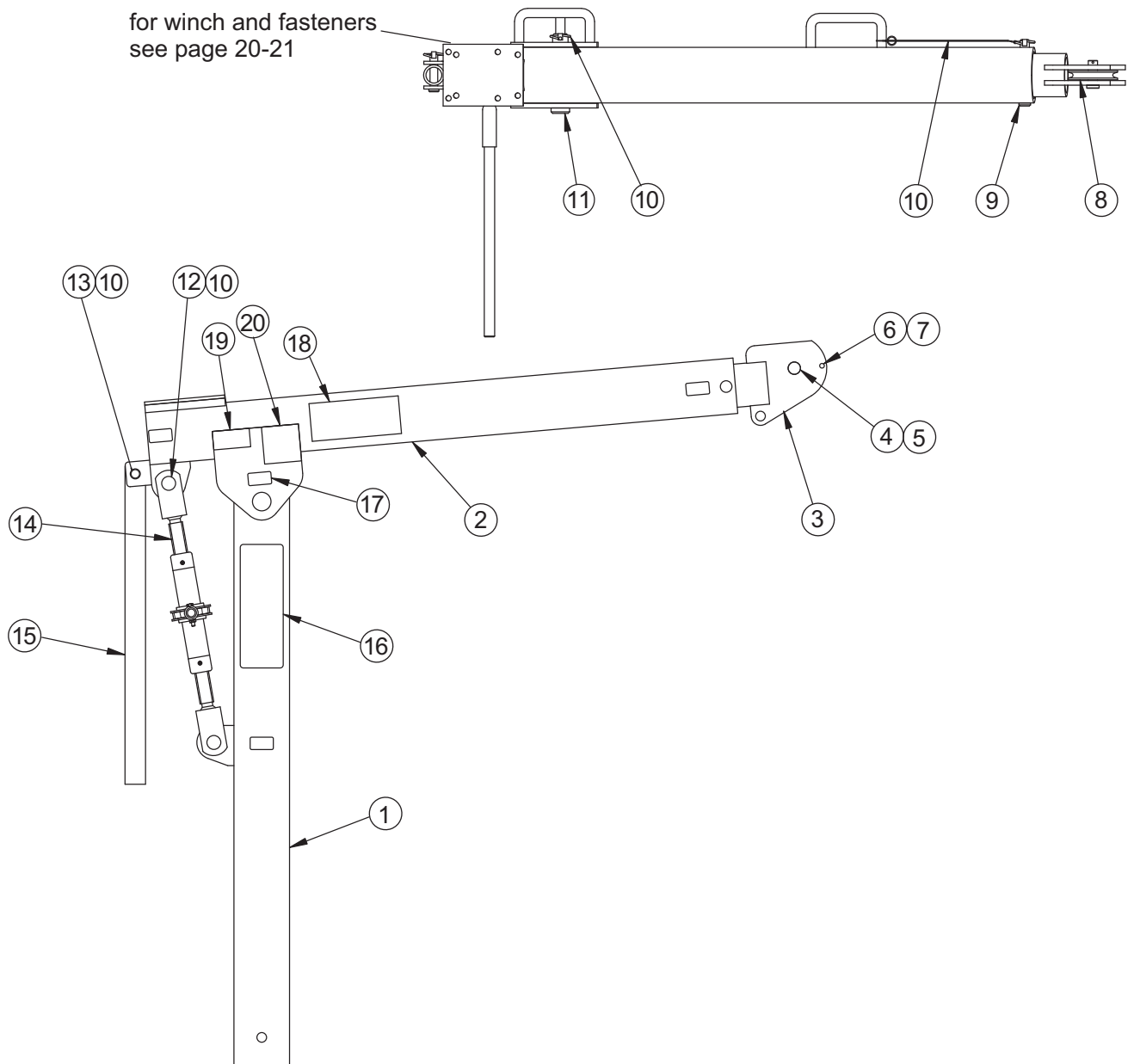

5110 and 5124 Series Winch		5110M1 Series 5124M1 Series		5110M2 Series 5124M2 Series		5110M3 Series 5124M3 Series		5110E2 Series 5124E2 Series	
item	description	part number	qty.	part number	qty.	part number	qty.	part number	qty.
1	WINCH	M4312PB-K	1	4WM2-K	1	M4312PBSS-K	1	4WP2-K	1
2	CAPSCREW HEXHD	A3355	4	A3355	4	A3355	4	A3355	4
3	HEX NUT	A3356	4	A3356	4	A3356	4	A3356	4

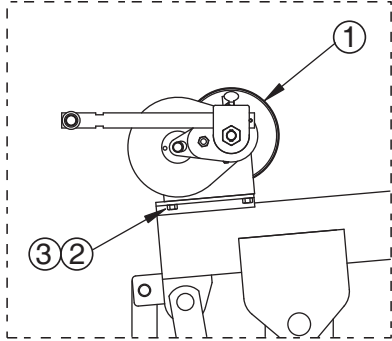

**5110M1 and 5110M3 Series
5124M1 and 5124M3 Series**

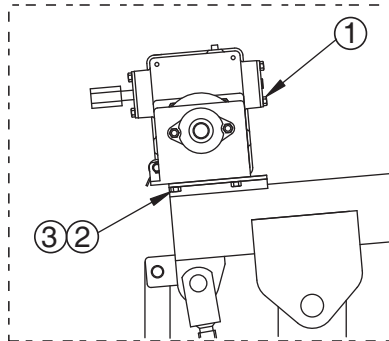

**5110M2 Series
5124M2 Series**

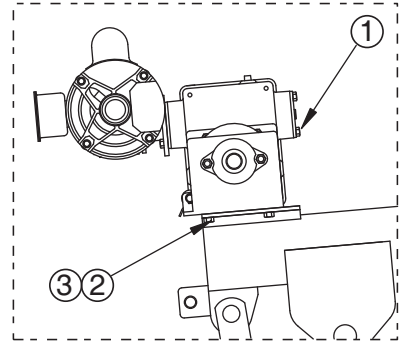

**5110E2 Series
5124E2 Series**

5124 Series Two Part Line Option		Model 5124TPL	
item	description	part number	qty.
1	Clevis Pin	A4438	1
2	Cotter Pin	A4305	1
3	Swivel 5/16 Chain Size	A7306	1
4	Snatch Block with Hook	A4779	1
5	Latch Kit	A9028	1

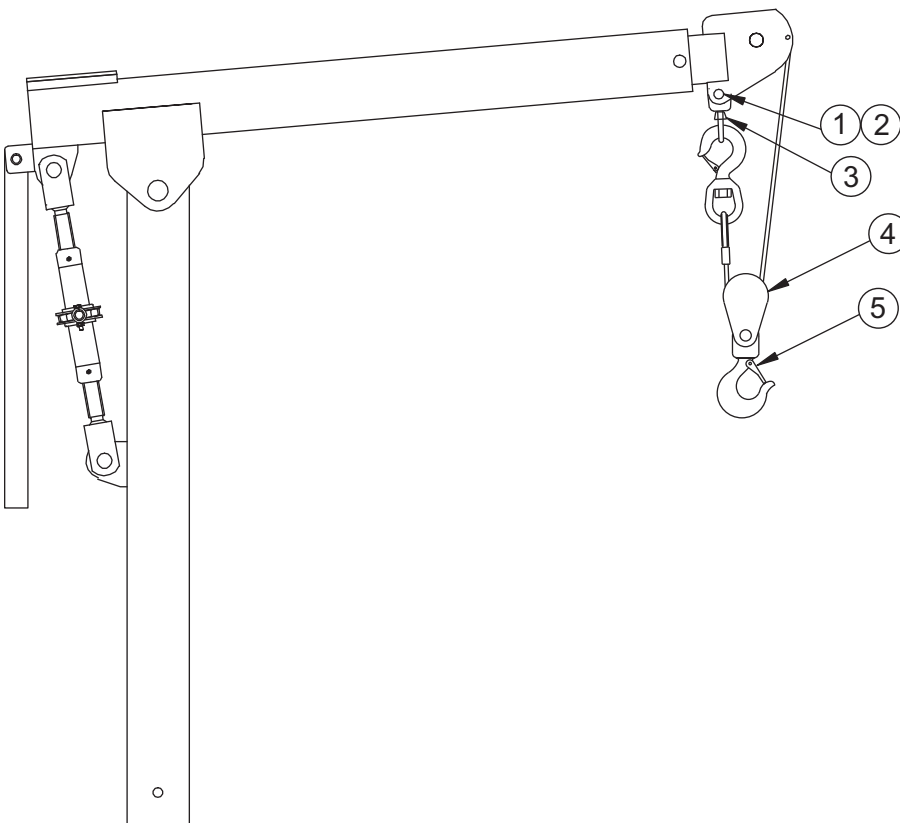

5110E4 and 5124E4 Series Winch		5110E4 5124E4 Red Fusibond		5110E4GAL 5124E4GAL Galvanized Finish		5110E4SS 5124E4SS Stainless Steel	
item	description	part number	qty.	part number	qty.	part number	qty.
1	POWER WINCH	4777-K	1	4777-K	1	4777-K	1
2	MOUNTING PLATE ASSEMBLY	C3114	1	C3114GAL	1	C3114	1
2a	MOUNTING PLATE	C3111RED	1	C3111GAL	1	C3111RED	1
2b	CAPSCREW HEXHD .375-16NC X .750	A2975	4	A2975	4	A2975	4
2c	WASHER HELSPRLK .375 X .683 X .094	A2926	4	A2926	4	A2926	4
2d	CAPSCREW HEXHD .312-18NC X 2.000	A5042	6	A5042	6	A5042	6
2e	HEX NUT NYLK .312-18NC	A2927	6	A2927	6	A2927	6
2f	FLAT WASHER SAE .312 X .688 X .065	A2924	6	A2924	6	A2924	6

5110E4DC and 5124E4DC Series Winch		5110E4DC 5124E4DC Red Fusibond		5110E4DCGAL 5124E4DCGAL Galvanized Finish		5110E4DCSS 5124E4DCSS Stainless Steel	
item	description	part number	qty.	part number	qty.	part number	qty.
1	POWER WINCH	4777DC-K	1	4777DC-K	1	4777DC-K	1
2	MOUNTING PLATE ASSEMBLY	C3114	1	C3114GAL	1	C3114	1
2a	MOUNTING PLATE	C3111RED	1	C3111GAL	1	C3111RED	1
2b	CAPSCREW HEXHD .375-16NC X .750	A2975	4	A2975	4	A2975	4
2c	WASHER HELSPRLK .375 X .683 X .094	A2926	4	A2926	4	A2926	4
2d	CAPSCREW HEXHD .312-18NC X 2.000	A5042	6	A5042	6	A5042	6
2e	HEX NUT NYLK .312-18NC	A2927	6	A2927	6	A2927	6
2f	FLAT WASHER SAE .312 X .688 X .065	A2924	6	A2924	6	A2924	6
3	CONTROL BRACKET	B3126	1	B3126	1	B3126	1
4	CAPSCREW SOXHD .250-20NC X 1.000	A4233	4	A4233	4	A4233	4
5	HEX NUT NYLK .250-20NC	A2963	4	A2963	4	A2963	4
6	FLAT WASHER	A4270	4	A4270	4	A4270	4

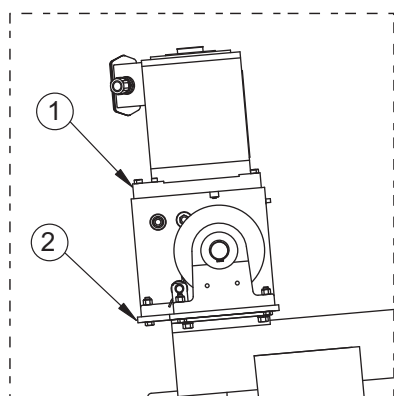

**5110E4 Series
5124E4 Series**

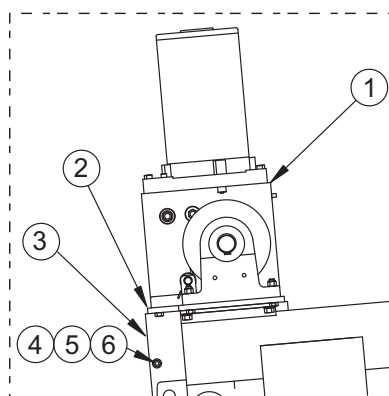

**5110E4DC Series
5124E4DC Series**

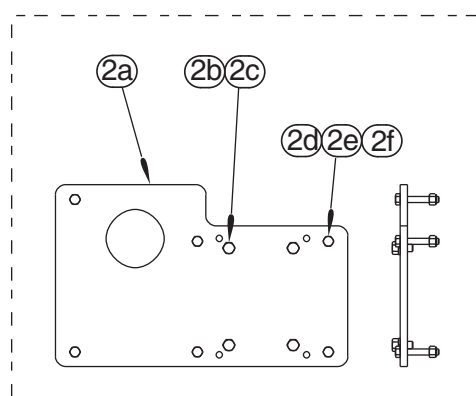

**C3114 Mounting
Plate Assembly**

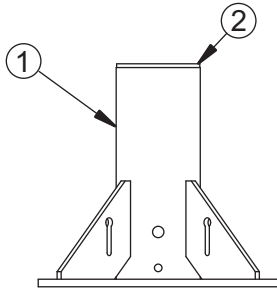

510 and 524 Series Pedestal Base

Pedestal Base							
510 Series ¹		510		510GAL		510SS	
item	description	part number	qty	part number	qty	part number	qty
1	BASE	C3876	1	C3876	1	C3840	1
2	FLANGE BEARING	B2450	1	B2450	1	B2450	1

¹ When ordering parts, be sure to specify whether the finish is red, galvanized or stainless.

Pedestal Base							
524 Series ¹		524		524GAL		524SS	
item	description	part number	qty	part number	qty	part number	qty
1	BASE	C3399	1	C3399	1	C3602	1
2	FLANGE BEARING	B3565	1	B3565	1	B3565	1

¹ When ordering parts, be sure to specify whether the finish is red, galvanized or stainless.

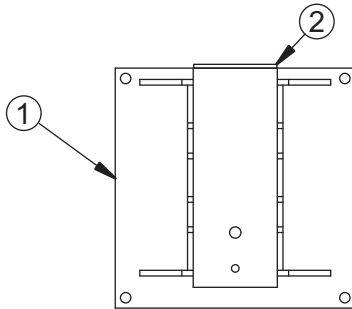

510W and 524W Series Wall Base

Wall Base							
510W Series ¹		510W		510WGAL		510SSW	
item	description	part number	qty	part number	qty	part number	qty
1	BASE	C3880	1	C3880	1	C3846	1
2	FLANGE BEARING	B2450	1	B2450	1	B2450	1

¹ When ordering parts, be sure to specify whether the finish is red, galvanized or stainless.

Wall Base							
524W Series ¹		524W		524WGAL		524SSW	
item	description	part number	qty	part number	qty	part number	qty
1	BASE	C3407	1	C3407	1	C3804	1
2	FLANGE BEARING	B3565	1	B3565	1	B3565	1

¹ When ordering parts, be sure to specify whether the finish is red, galvanized or stainless.

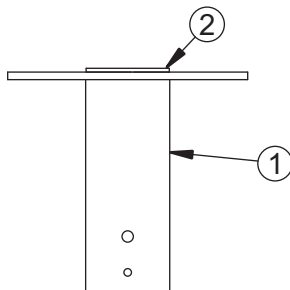

510W and 524W Series Socket Base

Socket Base							
510F Series ¹		510F		510FGAL		510SSF	
item	description	part number	qty	part number	qty	part number	qty
1	BASE	C3878	1	C3878	1	C3843	1
2	FLANGE BEARING	B2450	1	B2450	1	B2450	1

¹ When ordering parts, be sure to specify whether the finish is red, galvanized or stainless.

Socket Base							
524F Series ¹		524F		524FGAL		524SSF	
item	description	part number	qty	part number	qty	part number	qty
1	BASE	C3402	1	C3402	1	C3616	1
2	FLANGE BEARING	B3565	1	B3565	1	B3565	1

¹ When ordering parts, be sure to specify whether the finish is red, galvanized or stainless.

5110 Series Performance Characteristics ²										
wire rope dia.	wire rope length	load rating for 5110M1 and M3				load rating for 5110M2, E2, E4, and E4DC				lift below floor level (min – max) ¹
		position 1	position 2	position 3	position 4	position 1	position 2	position 3	position 4	
1/4 in	20 ft	1000 lb	700 lb	600 lb	500 lb	1000 lb	700 lb	600 lb	500 lb	1 – 5 ft
1/4 in	28 ft	1000 lb	700 lb	600 lb	500 lb	1000 lb	700 lb	600 lb	500 lb	9 – 13 ft
1/4 in	36 ft	1000 lb	700 lb	600 lb	500 lb	1000 lb	700 lb	600 lb	500 lb	17 – 21 ft
1/4 in	45 ft	1000 lb	700 lb	600 lb	500 lb	1000 lb	700 lb	600 lb	500 lb	26 – 30 ft
1/4 in	60 ft	1000 lb	700 lb	600 lb	500 lb	1000 lb	700 lb	600 lb	500 lb	41 – 45 ft
1/4 in	75 ft	–	–	–	–	1000 lb	700 lb	600 lb	500 lb	56 – 60 ft

5124 Series Performance Characteristics ²										
wire rope dia.	wire rope length	load rating for 5124M1 and M3				load rating for 5124M2, E2, E4, and E4DC				lift below floor level (min – max) ¹
		position 1	position 2	position 3	position 4	position 1	position 2	position 3	position 4	
1/4 in	20 ft	2000 lb	1600 lb	1300 lb	1000 lb	2000 lb	1600 lb	1300 lb	1000 lb	0 – 4 ft
1/4 in	28 ft	1800 lb	1600 lb	1300 lb	1000 lb	1700 lb	1600 lb	1300 lb	1000 lb	8 – 12 ft
1/4 in	36 ft	1600 lb	1600 lb	1300 lb	1000 lb	1600 lb	1600 lb	1300 lb	1000 lb	16 – 20 ft
1/4 in	45 ft	1600 lb	1600 lb	1300 lb	1000 lb	1500 lb	1500 lb	1300 lb	1000 lb	25 – 29 ft
1/4 in	60 ft	1300 lb	1300 lb	1300 lb	1000 lb	1300 lb	1300 lb	1300 lb	1000 lb	40 – 44 ft
1/4 in	75 ft	–	–	–	–	1200 lb	1200 lb	1200 lb	1000 lb	55 – 59 ft
5/16 in	20 ft	2000 lb	1600 lb	1300 lb	1000 lb	2000 lb	1600 lb	1300 lb	1000 lb	0 – 4 ft
5/16 in	28 ft	1700 lb	1600 lb	1300 lb	1000 lb	1600 lb	1600 lb	1300 lb	1000 lb	8 – 12 ft
5/16 in	36 ft	1500 lb	1500 lb	1300 lb	1000 lb	1400 lb	1400 lb	1300 lb	1000 lb	16 – 20 ft
5/16 in	45 ft	1400 lb	1400 lb	1300 lb	1000 lb	1400 lb	1400 lb	1300 lb	1000 lb	25 – 29 ft

5124 Series with 5124TPL Two-Part Line Kit Performance Characteristics ²										
wire rope dia.	wire rope length	load rating for 5124M1 and M3				load rating for 5124M2, E2, E4, and E4DC				lift below floor level (min – max) ¹
		position 1	position 2	position 3	position 4	position 1	position 2	position 3	position 4	
1/4 in	20 ft	2000 lb	1600 lb	1300 lb	1000 lb	2000 lb	1600 lb	1300 lb	1000 lb	-3 – 1 ft
1/4 in	28 ft	2000 lb	1600 lb	1300 lb	1000 lb	2000 lb	1600 lb	1300 lb	1000 lb	1 – 5 ft
1/4 in	36 ft	2000 lb	1600 lb	1300 lb	1000 lb	2000 lb	1600 lb	1300 lb	1000 lb	5 – 9 ft
1/4 in	45 ft	2000 lb	1600 lb	1300 lb	1000 lb	2000 lb	1600 lb	1300 lb	1000 lb	9 – 13 ft
1/4 in	60 ft	2000 lb	1600 lb	1300 lb	1000 lb	2000 lb	1600 lb	1300 lb	1000 lb	17 – 20 ft
1/4 in	75 ft	–	–	–	–	2000 lb	1600 lb	1300 lb	1000 lb	25 – 28 ft
5/16 in	20 ft	2000 lb	1600 lb	1300 lb	1000 lb	2000 lb	1600 lb	1300 lb	1000 lb	-3 – 1 ft
5/16 in	28 ft	2000 lb	1600 lb	1300 lb	1000 lb	2000 lb	1600 lb	1300 lb	1000 lb	1 – 5 ft
5/16 in	36 ft	2000 lb	1600 lb	1300 lb	1000 lb	2000 lb	1600 lb	1300 lb	1000 lb	5 – 9 ft
5/16 in	45 ft	2000 lb	1600 lb	1300 lb	1000 lb	2000 lb	1600 lb	1300 lb	1000 lb	9 – 13 ft

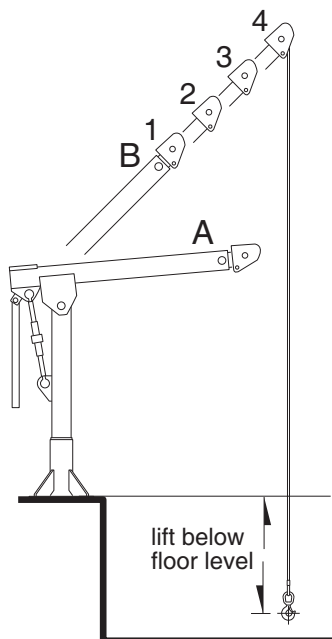

¹ Lift below floor level varies depending on boom position and base configuration. For longer lifts, please contact factory.
² Performance Characteristics are for standard products referred to in this manual. Non-standard products may vary from the original design. Contact Thern, Inc. for this information.



THERN

**Thern, Incorporated
5712 Industrial Park Road
Winona, MN 55987**

**PHN 507-454-2996
FAX 507-454-5282**

**EMAIL: info@thern.com
www.thern.com**